

# AUTOMATION PRODUCTS GROUP, INC.

**Operator's Manual**

## **DCR-1005 and DCR-1006**

Rev. A4, 10/08  
Doc. 9002664



**Automation Products Group, Inc.**

***APG...Providing tailored solutions for measurement applications***

Tel: 1/888/525-7300 • Fax: 1/435/753-7490 • [www.apgsensors.com](http://www.apgsensors.com) • E-mail: [sales@apgsensors.com](mailto:sales@apgsensors.com)

## Table of Contents

<i>Warranty</i> .....	3
<i>Introducing</i> .....	4
<i>Understanding Ultrasonics</i> .....	5
<i>Installation</i> .....	7
<i>Wiring</i> .....	10
<i>Programming</i> .....	11
<i>Error Indicators</i> .....	11
<i>Programming Modes</i> .....	12
<i>Operation</i> .....	13
<i>Filtering</i> .....	14
<i>Outputs</i> .....	16
<i>Applications</i> .....	21
<i>Calibration</i> .....	26
<i>Utilities</i> .....	28
<i>Quick Reference Sheet</i> .....	30
<i>Maintenance</i> .....	32
<i>DCR Specifications</i> .....	33
<i>DST Specifications</i> .....	34

## • Warranty and Warranty Restrictions

APG warrants its products to be free from defects of material and workmanship and will, without charge, replace or repair any equipment found defective upon inspection at its factory, provided the equipment has been returned, transportation prepaid, within 24 months from date of shipment from factory.

THE FOREGOING WARRANTY IS IN LIEU OF AND EXCLUDES ALL OTHER WARRANTIES NOT EXPRESSLY SET FORTH HEREIN, WHETHER EXPRESSED OR IMPLIED BY OPERATION OF LAW OR OTHERWISE INCLUDING BUT NOT LIMITED TO ANY IMPLIED WARRANTIES OF MERCHANTABILITY OR FITNESS FOR A PARTICULAR PURPOSE.

No representation or warranty, express or implied, made by any sales representative, distributor, or other agent or representative of APG which is not specifically set forth herein shall be binding upon APG. APG shall not be liable for any incidental or consequential damages, losses or expenses directly or indirectly arising from the sale, handling, improper application or use of the goods or from any other cause relating thereto and APG's liability hereunder, in any case, is expressly limited to the repair or replacement (at APG's option) of goods.

Warranty is specifically at the factory. Any on site service will be provided at the sole expense of the Purchaser at standard field service rates.

All associated equipment must be protected by properly rated electronic/electrical protection devices. APG shall not be liable for any damage due to improper engineering or installation by the purchaser or third parties. Proper installation, operation and maintenance of the product becomes the responsibility of the user upon receipt of the product.

Returns and allowances must be authorized by APG in advance. APG will assign a Return Material Authorization (RMA) number which must appear on all related papers and the outside of the shipping carton. All returns are subject to the final review by APG. Returns are subject to restocking charges as determined by APG's "Credit Return Policy".

## • **Introducing**

The DCR-1005 and DCR-1006 controller with DST series sensors were specifically designed to provide a rugged and reliable non-contact sensor system that is easily programmed yet flexible enough to use in a wide range of applications.

The DCR-1005 and DCR-1006 controllers have a 0.5 in. 4 character LCD display to show readings and parameters. The controller can be configured to monitor distance, level or volume. The DCR-1005 comes standard with four relay outputs. The DCR-1006 also includes an isolated 4 - 20 mA output.

The DST series sensors are non-contact ultrasonic sensors which measure the distance to a target through air. A list of available sensors can be found under DST Specifications, found at the end of this manual starting on page 35.

Typical applications include:

- Monitoring water levels in a well
- Determining material volume in a tank
- Obstacle avoidance
- Product dimensioning
- Loop control

• **Understanding Ultrasonics**

Ultrasonic sensors measure distance using a transducer to send out ultrasonic bursts. Each burst contains a series of 1-20 pulsed sound waves that emit in the shape of a cone, reflect off the target, and are received by the sensor. The time required for the sound burst to travel to and from the target is converted into a distance measurement by the sensor.

Ultrasonic sensing is affected by several factors including the target surface, distance, size, and angle. The following considerations will help ensure the best possible target conditions.

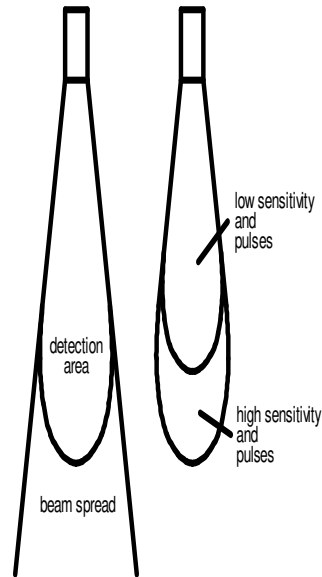

**Surface**

The ideal target surface is hard and smooth and perpendicular to the face of the transducer. This surface will reflect a greater amount of signal than a soft, sound wave absorbent surface. A target with poor sound wave reflection characteristics will reduce the operating distance of the sensor and decrease its accuracy.

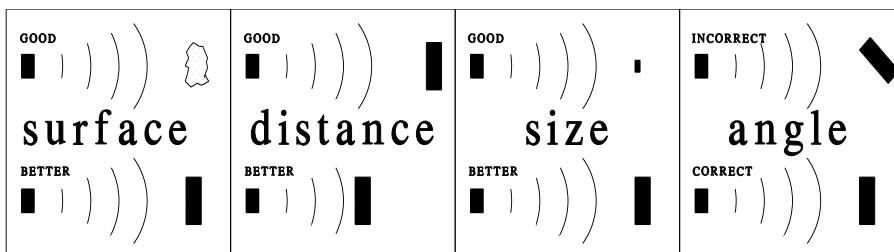

## Distance

The shorter the distance from the sensor to an object, the stronger the returning echo will be. Therefore, as the distance increases, the object requires better reflective characteristics to return a sufficient echo.

## Size

A large object will have a greater surface area to reflect the signal than a small one, therefore, a large target will be detected at a greater distance than a small target. The surface area recognized as the target is generally the portion closest to the sensor.

## Angle

The inclination of the object's surface facing the ultrasonic sensor affects the reflectivity of the object. The portion perpendicular to the sensor returns the echo. If the entire surface is at a great enough angle, the signal will be reflected away from the sensor and no echo will be detected. Generally a target at an angle greater than 5 degrees off perpendicular will not be detected.

## Environmental Conditions

Temperature, humidity, gases, dust, and pressure may also affect the sensor's performance. APG ultrasonic sensors automatically compensate for many of these conditions. However, these conditions can degrade the sensor's performance enough it may be necessary to use a longer-range sensor than normal conditions would require.

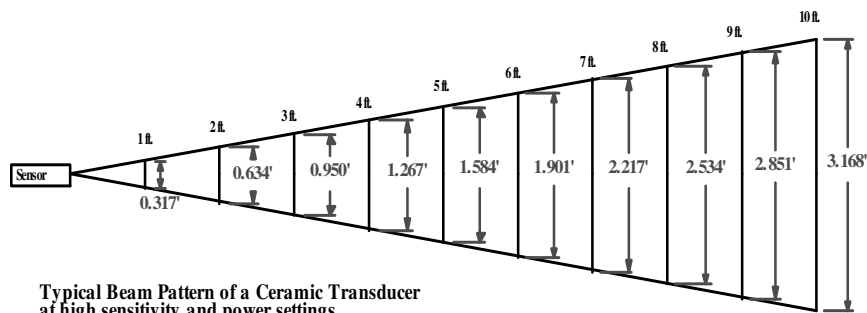

## • Installation

### Installing the DCR

The DCR-1005 and DCR-1006 should be installed using the 4 screws through 4 holes in the back of the enclosure. The enclosure must be mounted out of direct sunlight.

### Installing the DST

The DST sensor should be installed so that it has a clear sound path to the intended target. Mount the sensor away from tank walls and inlets. The path should be free from obstructions and as open as possible for the 9° off axis beam pattern. Follow the guidelines mentioned in “Understanding Ultrasonics”, found on page 5.

#### NPT and Flange Mounting

- Mounting in a coupler or half coupler welded to the top of tank. (see drawings below)
- Coupling should extend through the top of tank.
- Coupler must be aligned perpendicular to the target level.
- Screw sensor in only hand tight!
- To avoid false Echoes, the coupler should be installed where there is a clear sound path perpendicular to the detection surface and where the sound path will not intersect vessel fill spouts, rough vessel walls, ladders...etc.

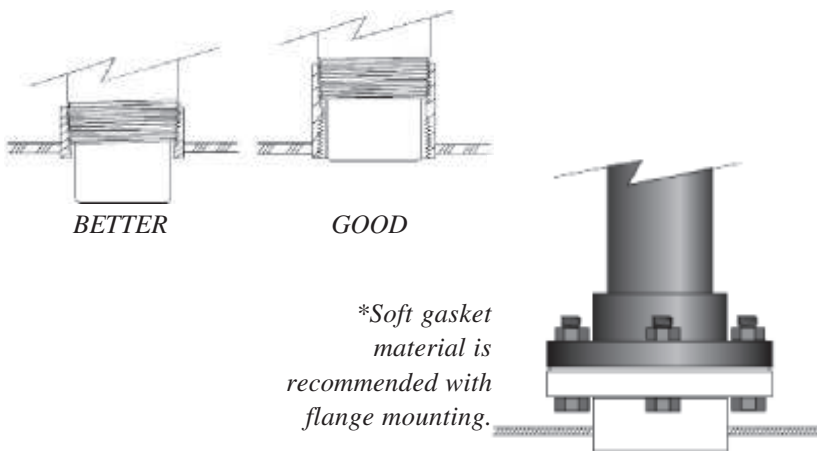

### Stand Pipe Mounting

The stand pipe should be as large in diameter and as short in length as possible. Mount the sensor above the highest anticipated material by at least the published blanking distance.

The stand pipe should be seamless to provide a smooth path for the sound waves to propagate into the tank. Because the sound waves will concentrate along the inside wall of the pipe, any seams from couplers, nipples, and welds will cause echo returns that will be picked up by the sensor. The sensor blanking will need to be changed to a distance greater than the length of the pipe (found on page 13; mode 5).

The end of the stand pipe should extend inside the tank and be cut to a 45° angle. Make sure that the cut is clean and free from burrs. If the standpipe is cut at 90°, there will develop a standing wave echo at the end of the pipe that will be seen by the sensor as a target. If a 45° cut is not feasible in your application, then the cut should be made as close to 45° as possible (often, even a 10° cut will shrink the standing wave enough to allow the sensor to see past it).

To avoid false Echoes, the stand pipe should be installed where there is a clear sound path perpendicular to the detection surface and where the sound path will not intersect vessel fill spouts, rough vessel walls, ladders...etc. Any angle off perpendicular will degrade the performance of the sensor.

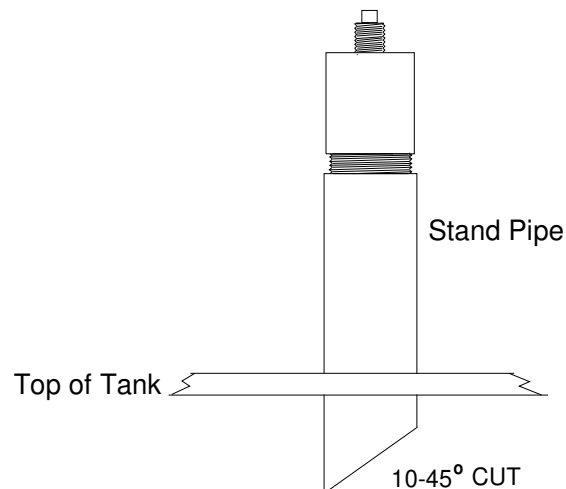



### Stilling Well Mounting

Provides access to difficult areas and eliminates problems with foam.

- Extend the pipe above the highest anticipated level by at least the published blanking distance.
- Provide a vent hole at the top of the tube. Keep the hole inside the blanking distance of the sensor to prevent false echoes.
- Use only in liquid materials that will not leave deposits on the inside of the pipe (material build-up will result in false echoes).
- Pipe must have smooth walls and should be seamless to provide a smooth path for the sound waves to propagate into the tank. Because the sound waves will concentrate along the inside wall of the pipe, any seams from couplers, nipples, and welds will cause echo returns that will be picked up by the sensor.

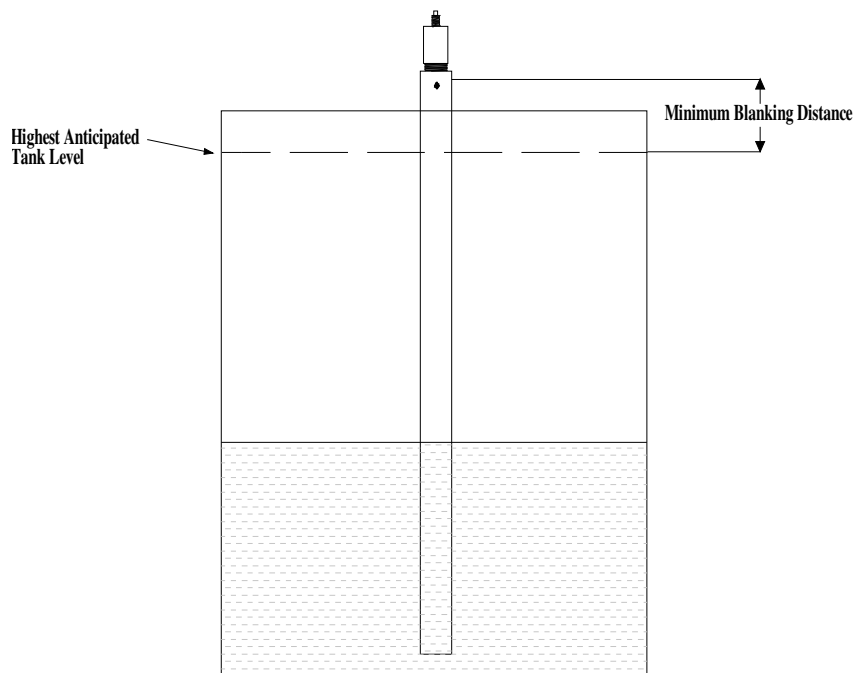

## • Wiring

**Step 1:** Depending on the DST cable version (coax or 2-conductor), connect the DST to the DCR Controller by way of the coaxial 'F' connector located on the outside of the DCR box, or use the terminal strip located inside the DCR box. The DST sensors can be mounted up to 2000 feet from the controller.

**Step 2:** To obtain access to the DCR's terminal strip, remove the DCR's polycarbonate cover by turning the 4 screws counterclockwise 1/4 turn. Remove the display board by removing the four 4-40 screws to expose the terminal strip.

**Step 3:** The DCR-1005 and DCR-1006 is shipped from the factory configured for 120 VAC input power.

<u>INPUT POWER</u>	<u>JUMP</u>	<u>JUMP</u>
120 VAC	2-3	4-5
240 VAC	3-4	N/A



**Step 4:** Wires can be pulled into the DCR-1005 and DCR-1006 through the strain reliefs on the enclosure. The screw terminal can be wired using solid or stranded wire between 16 - 22 AWG. Wires should be stripped, leaving a 0.4 in. bare wire. For wiring the 2-conductor DST, connect the red wire to DST (+) and the black and shield wire to the DST GND.

**Step 5:** Perform an internal check to ensure that all wires are properly connected and secured.

**Step 6:** Secure the Display Board and make the power connection. The LCD should light.

L1	L2	GND	24V	GND	DIG	4-20(+)	4-20(-)	DST(+)	GND	N.C.	COM	N.O.	N.C.	COM	N.O.	N.C.	COM	N.O.	N.C.	COM	N.O.
110-220 VAC			24V		Digital In	4-20		DST	TRIP 1	TRIP 2			TRIP 3			TRIP 4					

Automation Products Group, Inc.

**APG...Providing tailored solutions for measurement applications**

## • Programming

The DCR-1005 and DCR-1006 has a four-digit LCD readout and four red LED's labeled TRIPS 1, 2, 3, and 4. These LED's indicate the status of the relays. Four momentary push-buttons located under the cover, are used to program the DCR. The cover makes reading the displays easy while sealing the electronics and preventing the buttons from being accidentally bumped.

The different modes of the DCR can be easily accessed using the mode buttons, M-UP and M-DN. They operate similar to a digital watch. To cycle forward through the modes, hold down the M-UP key. To cycle backward through the modes, hold down the M-DN key.

To select a mode, press the M-UP or M-DN key until the desired mode number is displayed. Pressing either the V-UP or V-DN will display the selected mode setting on the LCD display.

To change the selected mode setting hold down the V-UP or V-DN key until the desired setting is displayed. Enter the new value by pressing either of the mode keys. The display will then show the DST distance reading.

## • Error Indicators

There are 4 error indicators which may appear on the display given the appropriate conditions.

**E1** indicates a short in the DST Power connection or termination.

**E2** indicates that a sensor is not connected or the sensor is not communicating.

**E3** indicates a Loss of Echo condition. The sensor is not able to acquire a target within the range of the sensor.

**----** (**dashes**) indicate that the number to be displayed is larger than the display will allow. To correct this condition, try adjusting the Decimal Position (Mode 2) or changing the multiplier (Modes 29 and 30). This indication may also result from a negative number to be displayed.

## • Programming Modes

- 1) Operation (Modes 1-5)
- 2) Filtering (Modes 6-11)
- 3) Outputs (Modes 12-27)
- 4) Applications (Modes 28-37)
- 5) Calibration (Modes 38-39)
- 6) Utilities (Modes 40-42)

### Mode Sequence

For best results when programming your DCR, follow the steps below. Following the steps in sequence will eliminate most of the problems encountered when setting up the DCR controller.

1. **MODES 1-2** Determine units to be displayed
2. **MODES 4-6** Determine settings to get a reliable distance reading on your target
3. **MODES 7-11** Determine appropriate filtering for your application
4. **MODE 3** Select application type (MODE 2 will need to be adjusted for volume applications)
  1. Distance: skip to step 5
  2. Volume/Level: setup Modes 28-34
5. **MODES 12-23** Setup relay outputs. Remember to program relays in the units of measurement be displayed and to disable relays that are not being used.
6. **MODES 24-27** Setup analog output
7. **MODE 35** Set temperature compensation
8. **Advanced setup (not required in most applications) MODES 26-27, 36-45**

## Operation

The operation modes are used to perform basic initialization of the DCR.

<u>MODE</u>	<u>DESCRIPTION</u>	<u>PARAMETERS</u>	<u>EXPLANATION</u>
1	<i>Units</i>	Range = 1 - 3 1 - inches 2 - feet 3 - meters Default = 2	Selects the units to be displayed.
2	<i>Decimal Point</i>	Range = 0000.- 0.000 Default = 00.00	Selects the decimal point position.
3	<i>Operating Mode</i>	Range = 1 - 2 1 - distance 2 - volume/level Default = 1	Selects mode of measurement for the application.
4	<i>Sensitivity</i>	Units = % Range = 0 - 100 %	Sets sensitivity (or gain) as a percentage of maximum.

*If using a DST version 2000 sensor, Mode 4 will display the selected sensor's sensitivity. The sensitivity is not user adjustable in these models.*

5	<i>Blanking</i>	Units = mode 1 Range = 0 - 36 ft. Default = dependant on DST model	Sets a dead zone in front of the DST where echoes are ignored. Keep above DST's minimum specification.
6	<i>Pulses</i>	Range = 1-20 Default = 16	Sets the number of pulse waves sent in each ultrasonic burst. Adjusts the strength of the transmitting signal.

*If using a DST version 2000 sensor, Mode 6 will display the sensor's selected pulse setting. The pulse setting is not user adjustable.*

## Filtering

The filtering modes are provided to change how fast the system will respond to changes. The default settings should be appropriate for most level applications, however, the delays and windows can be changed to increase or decrease reaction time and filtering.

<u>MODE</u>	<u>DESCRIPTION</u>	<u>PARAMETERS</u>	<u>EXPLANATION</u>
7	<i>Sample Rate</i>	Units = milliseconds Range = 80 - 9999 Default = 120	Sets the delay between sensor samples (readings).
8	<i>Samples Averaged</i>	Units = Samples Range = 1 - 50 Default = 20	Sets the number of samples to be averaged in the buffer memory on a first in first out basis.
9	<i>Out-of-Range</i>	Units = samples Range = 1 - 50 Default = 10	Sets the number of out-of range samples in succession that will be ignored before the new target is accepted.
10	<i>Filter Window</i>	Units =Mode 1 Range = 0 - 20 ft. Default = 2.00 ft.	Sets the window of acceptance. The window is + or - this distance from the current reading. If a sample distance is outside of this window it will be ignored the number of times set in mode 9.
11	<i>Loss of Echo Delay</i>	Units = seconds Range = 0 - 9999 Default = 5	Sets the delay in seconds before the output will show a loss of echo condition. Allows the controller to maintain the current level indication for temporary loss of echo conditions. During a loss of echo condition the controller will maintain the last reading for the time frame indicated in seconds.

**Example: Rapid Level Changes**

If the DCR's filtering is too slow and the level to be monitored is changing rapidly, the display will seem to jump between readings instead of scrolling smoothly as the level changes. To reduce the filtering and quicken the response, mode 7 or 8 should be changed.

<u>MODE</u>	<u>VALUE</u>	<u>DESCRIPTION</u>
7	0.125	Sets the sampling interval to a shorter time requirement, thus decreasing the interval between samples from the default of 250 ms to 125 ms.
8	10	Decrease the samples averaged so that the DCR can respond faster.

**Example: Ignoring Intermittent Obstacles**

To prevent agitators, splashing, or other intermittent objects from being detected even though they are occasionally in the ultrasonic detection beam:

<u>MODE</u>	<u>VALUE</u>	<u>DESCRIPTION</u>
9	40	Increase the Out-of-Range Samples before updating. If the sample rate is set to 0.500 seconds, and mode 9 set to 40, then the DCR will require at least $40 * 0.5$ or 20 seconds of readings outside of the filter window (Mode 10) before the display and outputs will recognize a new target.
10	0.3 ft.	Reduce the filter window for good readings. This will help qualify only echoes at the surface level. If the level changes rapidly, the average level indication may lag behind the actual level. If this occurs, the actual level may move outside the filter window if the window size is too small.

## Outputs

The DCR-1005 and DCR-1006 contain 4 SPDT relays which are capable of handling a 10 amp load. These relays have programmable BEGIN and END points as well as TYPE of operation. The LED's on the DCR indicate the status of the relays. The programming units must be the same as those displayed. i.e. If gallons are displayed the trip location should be set in gallons.

<u>MODE</u>	<u>DESCRIPTION</u>	<u>PARAMETERS</u>	<u>EXPLANATION</u>
12	<i>Begin Trip 1</i>	Units = mode 1 Default = 2.5 ft.	Sets the begin point of Trip 1.
13	<i>End Trip 1</i>	Units = mode 1/mode 3 Default = 2.9 ft.	Sets the end point of Trip 1.
14	<i>Trip 1 Type</i> See Trip Type Explanation for details.	Range = 0 - 7 Default = 0	Selects the type of function Trip 1 will perform.
15	<i>Begin Trip 2</i>	Units = mode 1/mode 3 Default = 3 ft.	Sets the begin point of Trip 2.
16	<i>End Trip 2</i>	Units = mode 1/mode 3 Default = 3.4 ft.	Sets the end point of of Trip 2.
17	<i>Trip 2 Type</i> See Trip Type Explanation for details.	Range = 0 - 7 Default = 0	Selects the type of function Trip 2 will perform.
18	<i>Begin Trip 3</i>	Units = mode 1/mode 3 Default = 3.50 ft.	Sets the begin point of Trip 3.
19	<i>End Trip 3</i>	Units = mode 1/mode 3 Default = 3.90 ft.	Sets the end point of Trip 3.
20	<i>Trip 3 Type</i> See Trip Type Explanation for details.	Range = 0 - 7 Default = 0	Selects the type of function Trip 3 will perform.
21	<i>Begin Trip 4</i>	Units = mode 1/mode 3 Default = 4.0 ft.	Sets the begin point of Trip 4.
22	<i>End Trip 4</i>	Units = mode 1/mode 3 Default = 4.40 ft.	Sets the end point of of Trip 4.
23	<i>Trip 4 Type</i> See Trip Type Explanation for details.	Range = 0 - 7 Default = 0	Selects the type of function Trip 4 will perform.



**Trip Type Explanation**

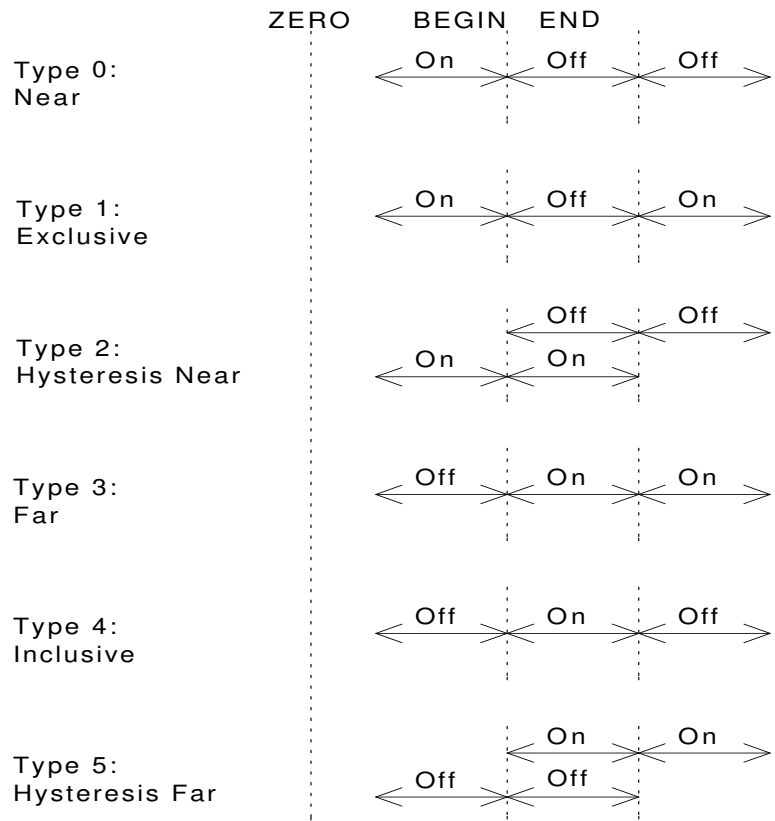

Type 6: Trip Point Disable

Type 7: Relay remains closed (trip light on) unless an error is detected in communication, loss of echo, or loss of power.

NOTE: The Zero line represents the face of the sensor when operating in "Distance" mode and the bottom of the tank when indicating volume or level.

NOTE: TRIP END should always be a larger value than TRIP BEGIN.

**Example: Relay Settings for Distance to Level**

A 10 ft. deep lift station requires that a pump turn on when a level is closer than 6 ft to the DST. The pump must stay on until the level drops to 9 ft. from the DST. An alarm relay is to be energized under normal operation and should open for failure in power, communication, invalid readings, high level closer than 5 ft., or loss of echo.

To program the DCR-1005 and DCR-1006 for this application, the following modes must be set:

<u>MODE</u>	<u>VALUE</u>	<u>DESCRIPTION</u>
5	2.00	Do not set closer than the minimum distance recommended for the DST sensor type being used.
12	6.00	Set the pump begin point at 6 ft. from the DST.
13	9.00	Set the pump end point at 9 ft. from the DST.
14	2	Use the hysteresis near type of gate to keep the pump on while pumping the level down.
15	5.00	Begin the alarm trip point at 5 ft.
16	10.00	End the alarm trip point at 10 ft. because any reading greater will indicate loss of echo or communication.
17	4	Any signal higher than 5 ft. or lower than 10 ft. will cause the alarm relay to open.

**Example: Relay Settings For Product Level rather than Distance to Level**

A 10 ft. deep lift station requires that a pump turn on when a level reaches 4 ft. and stay on until the level drops to 1 ft. from the bottom of the station. An alarm relay is to be energized under normal operation and should open for failure in power, communication, invalid readings, high level above 5 ft., or loss of echo.

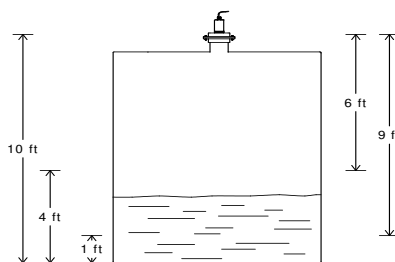

To program the DCR-1005 and DCR-1006 for this application, the following modes must be set:

<u>MODE</u>	<u>VALUE</u>	<u>DESCRIPTION</u>
3	2	Select Volumetric Monitoring for this application so the display will indicate the distance from the tank bottom to the level.
5	2.00	Do not set closer than the minimum distance recommended for the DST sensor type being used.
12	1.00	Set the pump begin point at 1 ft. from the bottom.
13	4.00	Set the pump end point at 4 ft. from the bottom.
14	5	Use the hysteresis far type of trip to keep the pump on while pumping the level down.
15	0.00	Begin the alarm trip point at the bottom because any signal below the zero point will indicate loss of echo or communication.
16	5.00	End the alarm trip point at 5 ft. for high level alarm.
17	4	Any signal higher than 5 ft. or lower than 0 ft. will cause the alarm relay to open.
28	1	Select a Flat Bottom Tank.
31	10	Distance from sensor to bottom of tank. The Controller subtracts the measured distance from the Tank Span to display level.

### Analog

The DCR-1006 has an Isolated 4-20 mA circuitry. To set up this feature, enter the two end points. For performing a distance to level measurement, the zero point of distance will be at the transducer and the 4-20 limits will be programmed in the same units as mode 1. For volumetric monitoring, the zero point will be at the empty point of the tank and the end points must be set in the units used in the volume measurement. Keep this in mind when referring to the diagram below. Remember that this circuit is Loop Powered. Power must be supplied to the 4-20 mA terminal for this feature to operate.

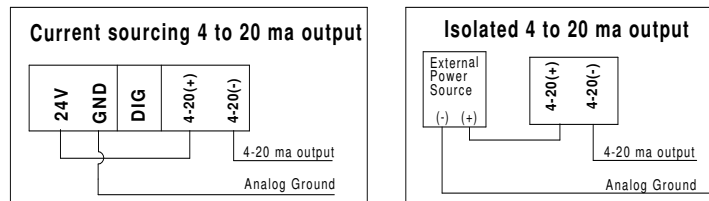

<u>MODE</u>	<u>DESCRIPTION</u>	<u>PARAMETERS</u>	<u>EXPLANATION</u>
24	4 mA distance	Units = mode 1 Default = 3.00 ft.	Sets the minimum value of the analog output slope
25	20 mA distance	Units = mode 1 Default = 4.00 ft.	Sets the maximum value of the analog output slope
26	4 mA calibration	Approx. 5000	Fine tunes the minimum current sourced on the analog output
27	20 mA calibration	Approx. 5000	Fine tunes the maximum current sourced on the analog output

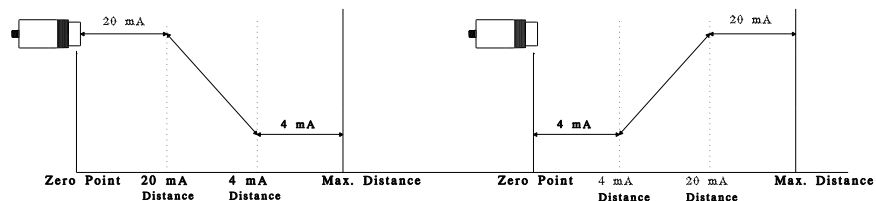

## Applications

The DCR Controller can be configured for two different types of applications. They are:

- **Distance:** Measuring the distance to an object.
- **Volume:** Determining the volume, or level of a product in a tank.

### DISTANCE

Measuring the distance to a target is the most basic application. The DCR Controller will do this without any special settings.

#### Example: Distance Measurement

A batch plant operator needs a display to show the level of rock in a hopper 5 m deep.

To program the DCR for this application, the following values must be entered in the modes indicated. Many of them are the same as the preset values but are shown again for example purposes.

<u>MODE</u>	<u>VALUE</u>	<u>DESCRIPTION</u>
1	3	Set units to meters because the output is to be displayed in meters.
2	.0	Change the display so that it will have a 10 cm resolution.
3	1	Select distance monitoring for application.
4	80	Adjust percent of sensitivity. (This would not apply for DST sensor operating with Auto-Sense.)
5	0.60	Do not set closer than the minimum distance recommended for the DST sensor type being used.
6	9	Set strength of transmit signal.

## VOLUME

A very popular use for the DCR is to display for the amount of product in a tank. If tank type 0 is selected, the zero point is at the DST, and the display will show the distance to the product. Selecting tank type 1 is the most common setting for DCR this allows the display to show the level of the product in the tank. This setting would be used for any style of tank to indicate level, the zero point is moved to the bottom of the tank. It is also used for volume calculations of flat bottom tanks. If tank type 2 - 5 are selected, the zero point is the bottom of the tank, and the controller will compute product volume using the units selected in mode 1. These tank types are used only if a volumetric readout is desired.

<u>MODE</u>	<u>DESCRIPTION</u>	<u>PARAMETERS</u>	<u>EXPLANATION</u>
28	<i>Tank Type</i>	Range = 0 - 5 0 - distance to level 1 - level indication 2 - hzontal flat ends 3 - hzontal sphere ends 4 - spherical tank 5 - conical bottom Default = 0	Selects the type of tank to be monitored. Set by V-UP or V-DN Types 2-5 converts to volume using units selected in mode. If feet is the unit of measure then display will read cubic feet of product.
29	<i>Constant Above Decimal Point</i> [Note: The relay and analog outputs must be programmed in the same units used here.]	Range = 0 - 9999 Default = 1	Sets the portion of the multiplier above the decimal point. Used for converting distance to volume or converting from one unit to another for example ft <sup>3</sup> to gallons.
30	<i>Constant Below Decimal Point</i>	Range = .0000 - .9999 Default = .0000	Sets the portion of the multiplier below the decimal point.
31	<i>Span</i>	Units = mode 1 Default = 12.00 ft.	Sets distance from the transducer to bottom of the tank.
32	<i>Tank Length</i>	Units = mode 1 Default = 10.00 ft.	Sets the length of a horizontal tank or the length to a conical bottom.
33	<i>Length of Spherical Ends or Cone</i>	Units = mode 1 Default = 2.00 ft.	Sets the length of the bottom cone or spherical ends (tank type 3 or 5)
34	<i>Tank Radius</i>	Units = mode 1 Default = 5.00 ft.	Sets the radius of the cylinder (not used in tank type 0 or 1)

**Conversion Factors**

It is often desirable to display a volume output in units of measurement other than cubic feet, inches, or meters. In order to do this you need to apply a conversion factor. For tank types 2-5 the conversion factor needs to be entered into modes 29- 30, and the DCR does the rest. For flat bottom tanks (type 1), the conversion factor needs to be multiplied by the area of the bottom of the tank, and the result entered into modes 29-30. This is only necessary for type 1 tanks.

**Common Conversion Factors:**

- Cubic Feet (ft.<sup>3</sup>) x 7.4805 = Gallons
- Cubic Feet (ft.<sup>3</sup>) x 28.317 = Liters
- Cubic Inches (in.<sup>3</sup>) x 0.00433 = Gallons
- Gallons x 3.7854 = Liters

**Common Area Formulas**

**(for use with type 1 tanks):**

Area of a Circle =  $P \times r^2$

Area of a Square or Rectangle =  $L \times W$

For each tank type, as shown below, values for modes 31-34 must be entered. If a mode is not indicated in the drawing, the value stored in that mode setting will be ignored. For example, if tank type 4 is selected in Mode 28, only Modes 31 and 34 will be used in calculations. Values in Modes 32 and 33 are ignored. It is not necessary to set unused Modes to 0.

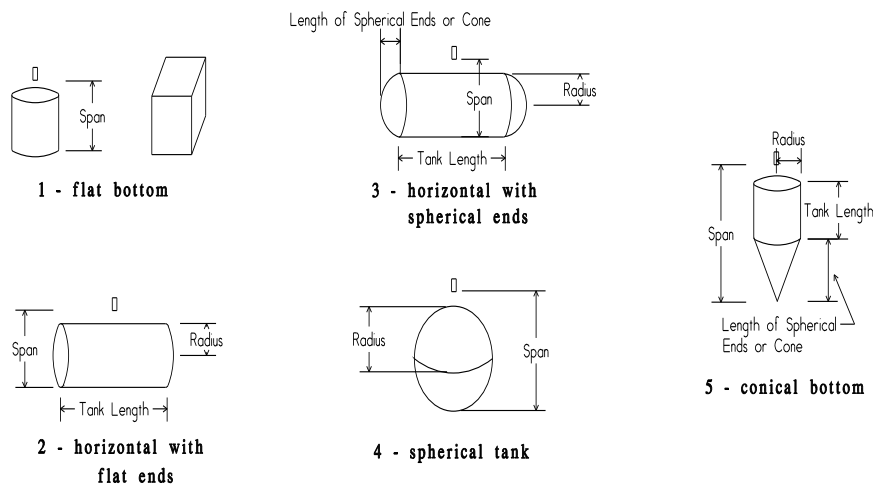

**Example: Volumetric Setting for a Horizontal Cylindrical Tank**

Gallons of diesel fuel need to be displayed in a horizontal cylindrical tank. The dimensions of the tank are 11 ft. span, 10 ft. length and a radius of 5 ft. To convert the volume (cubic feet) to gallons requires a multiplier of 7.4805. If relay and analog outputs were to be used, they must be programmed in gallons.

To program the DCR-1006 for this application, the following modes must be changed from their preset values.

<u>MODE</u>	<u>VALUE</u>	<u>DESCRIPTION</u>
1	2	Set units to feet.
2	0	Set the decimal to the right to prevent display overflow.
3	2	Select Volume Monitoring for application.
28	2	Set the tank type to 2 for horizontal tank.
29	7	Converting ft. <sup>3</sup> to gallons, multiplier above decimal point.
30	4805	Converting ft. <sup>3</sup> to gallons, multiplier below decimal point.
31	11.00	Set the distance from the DST to the bottom of the tank.
32	10.00	Set the length of the tank.
34	5.00	Set the tank radius of 5 ft.



**Example: Volumetric Setting for a Vertical Cylindrical Flat Bottom Tank**

Liters of DI water need to be displayed in a vertical cylindrical tank. The dimensions of the tank are 96 in. tall and 48 in. in diameter. In order to display the desired indication of liters a multiplier must be calculated. The multiplier is calculated based on the units selected in Mode 1. In this case it is inches (Mode 1 set to 1). If no multiplier is input the controller will display the distance in inches from the bottom of the tank. We will show how to program this application in 2 steps. First setting up the controller to display the level of the liquid in the tank, second showing how to convert that level indication to display in liters

To indicate the level of water in the tank, make the following adjustments:

<u>MODE</u>	<u>VALUE</u>	<u>DESCRIPTION</u>
1	1	Sets units to inches
3	2	Selects the operating mode to calculate level/volume
28	1	Selects the type of tank to be monitored.
31	96.0	Sets the distance from the transducer to the bottom of the tank.

This will display the level of water in the tank in inches.

To convert the read out so it displays the volume in liters we calculate the volume per unit of measure. In this case, liter/inch.

The volume of a cylinder is calculated by the following formula:

$$(Pi)(R^2)(H) = \text{Volume in cubic inches}$$

$$Pi = 3.1415927$$

$$R = \text{Radius of tank in this example } 48 \text{ in.} / 2 = 24 \text{ in.}$$

$$H = \text{Height of the cylinder. We are concerned only about volume per inch so } H = 1$$

Inserting the radius into this equation -  $3.1415927 \times 24^2 \times 1 = 1,809.216$  cubic inches

Cubic inches are converted to liters by multiplying it by 0.01639.

So, the multiplier is calculated by  $0.01639 \times 1,809.216 = 29.6530$  liters/inch

<u>MODE</u>	<u>VALUE</u>	<u>DESCRIPTION</u>
2	0	Move decimal point all the way to the right
29	29	Multiplier above the decimal point
30	6586	Multiplier Below the decimal point

### Temperature Compensation

As air temperature changes, so does the speed of sound. This change can cause 0.18% drift in distance for every degree C change. Mode 35 allows compensation in the readings for this change. The DST contains an internal thermistor which measures temperature in degrees F. By turning temperature compensation on, the effects of temperature changes are be reduced.

For the DST temperature sensor to operate properly, it must be shielded from radiant heat. Because the temperature sensor is internal to the DST, it requires several minutes to react to air temperature changes.

<u>MODE</u>	<u>DESCRIPTION</u>	<u>PARAMETERS</u>	<u>EXPLANATION</u>
35	Temperature Compensation	Range = 0 - 2 0 = OFF 1 = ON 2 = Current Temp. Default = OFF	Selects internal temperature compensation for changes in the speed of sound, on, off, or view sensor temperature set by V-UP or V-DN.

### Calibration

For most open air applications, the factory-set calibration should be correct. Variations between the distance measured by the DCR/DST System and the actual distance are caused by environmental conditions such as temperature, humidity, or chemical atmospheres. These environments can be compensated for by using a calibration factor which alters the reading to match the application conditions.

<u>MODE</u>	<u>DESCRIPTION</u>	<u>PARAMETERS</u>	<u>EXPLANATION</u>
36	Distance Offset	Units = mode 1 Range = 0.000 - 9999 Default = 0	Sets an offset for the display when measuring distance to a level.
37	Offset Polarity	Range = 0,1 0 = Subtract 1 = Add Default = NEG	Selects the direction of the offset. adds or subtracts offset to reading. Set by V-UP or V-DN.
38	Calibration Above the Decimal Point	Range = 0 - 9999 Default = 1	Sets the integer portion of the calibration factor.
39	Calibration Below the Decimal Point	Range = .0000-.9999 Default = 0	Sets the fractional portion of the calibration factor

**Example: Calibration****1 Point Calibration**

The Calibration Factor is used to bring the displayed reading in line with the measured distance. To obtain the measured distance, measure from the level to be detected to 0.5 in. behind the DST face. (0.5 in. behind the DST face is the electrical zero of the sensor.) The calibration factor is determined by dividing the actual distance measured, by the displayed distance. Enter this number in the calibration modes 38 and 39.

**2 Point Calibration**

If a more precise calibration is required, a two point calibration should be used. This is accomplished by using the linear equation of  $Y = AX + B$  where;

$Y = \text{Measured distance}$

$X = \text{DCR Reading}$

$A = \text{Multiplier}$

$B = \text{Offset}$

The multiplier (A) can be determined by taking ultrasonic readings at two known distances and dividing the difference of the known distances (D) by the difference of the ultrasonic (U) readings  $(A) = (D_2 - D_1) / (U_2 - U_1)$  where;

$D_2 = \text{far known distance}$

$U_2 = \text{Ultrasonic reading at } D_2$

$D_1 = \text{close known distance}$

$U_1 = \text{Ultrasonic reading at } D_1$

Enter this multiplier in Modes 38 and 39. The multiplier can then be entered in the above equation to calculate the offset  $B = D_2 - (A)U_2$ . The offset should be entered using Modes 36 and 37.

## Utilities

### Input Select

Allows the customer to use either a DST type sensor or other APG sensors with a pulse width output (digital) to drive the display.

<u>MODE</u>	<u>DESCRIPTION</u>	<u>PARAMETERS</u>	<u>EXPLANATION</u>
40	Input Select	Range = 0,1 0 = DST Sensor 1 = Pulse Width Default = 0	Selects which type of sensor input to accept.

### Reset

When the DCR is powered up, '0' is loaded in mode 41. This saves the user-selected modes into the DCR. If the mode adjustments get scrambled or if the factory preset values are wanted, press the V-UP. If "1" is entered into this mode, all of the parameters will be "RESET" to their factory defaults.

<u>MODE</u>	<u>DESCRIPTION</u>	<u>PARAMETERS</u>	<u>EXPLANATION</u>
41	Reset	Range = 0,1 Default = 0	Entering a 1 here will reset the DST to its factory default values.

### Software Version

Mode 42 displays the software version for the DCR. The value corresponds to the operating version and the approximate date of manufacture.

<u>MODE</u>	<u>DESCRIPTION</u>	<u>PARAMETERS</u>	<u>EXPLANATION</u>
42	Software Version		Displays the software version

**Extended Range**

Modes 43 - 44 allows the DCR to display ranges greater than 50 ft. These modes are enabled only in DST's with extended range.

<u>MODE</u>	<u>DESCRIPTION</u>	<u>PARAMETERS</u>	<u>EXPLANATION</u>
43	Range Selection	Range = 0,1 0 = 1 - 35 ft. Range 1 = 1 - 72 ft. Range Default = 0	Some DSTs will allow a detection range of up to 72 ft. This parameter enables the DCR to display that distance.
44	Maximum Range	Range = 1 - 72 ft. Default = 35 ft.	This parameter works only with 72 ft. DSTs and enables the user to limit the maximum distance.

**AutoSense**

Modes 45 disables or enables the AutoSense feature on selected models.

<u>MODE</u>	<u>DESCRIPTION</u>	<u>PARAMETERS</u>	<u>EXPLANATION</u>
45	AutoSense	Range 0,1 0 = OFF 1 = ON Default = 0	Sensors with the extended range software can have the AutoSense feature disabled or enabled.

• **Quick Reference Sheet**

<u>MODE</u>	<u>DESCRIPTION</u>	<u>PARAMETERS</u>
<b>Operation</b>		
1	Units	_____
2	Decimal Point	_____
3	Operating Mode	_____
4	Sensitivity	_____
5	Blanking	_____
6	Pulses	_____
<b>Filtering</b>		
7	Sample Rate	_____
8	Samples Averaged	_____
9	Out-of-Range Sample	_____
10	Out-of-Range Span	_____
11	Loss of Echo Delay	_____
<b>Relay</b>		
12	Begin Trip 1	_____
13	End Trip 1	_____
14	Trip 1 Type	_____
15	Begin Trip 2	_____
16	End Trip 2	_____
17	Trip 2 Type	_____
18	Begin Trip 3	_____
19	End Trip 3	_____
20	Trip 3 Type	_____
21	Begin Trip 4	_____
22	End Trip 4	_____
23	Trip 4 Type	_____

<u>MODE</u>	<u>DESCRIPTION</u>	<u>PARAMETERS</u>
<b>Analog</b>		
24	4 mA Distance	_____
25	20 mA Distance	_____
26	4 mA Calibration	_____
27	20 mA Calibration	_____
<b>Volume</b>		
28	Tank Type	_____
29	Mult Above	_____
30	Mult Below	_____
31	Span	_____
32	Tank Length	_____
33	Sphere. Length	_____
34	Tank Radius	_____
<b>Calibration</b>		
35	Temp Comp	_____
36	Distance Offset	_____
37	Offset Polarity	_____
38	Calibration Above	_____
39	Calibration Below	_____
<b>Utilities</b>		
40	Input Select	_____
41	Reset	_____
42	Software Version	_____
<b>Extended Range</b>		
43	Range Select	_____
44	Max. Range	_____
<b>Extended Range</b>		
45	AutoSense	_____

- **Maintenance**

The DCR-1005 /1006 controller and DST sensors do not require maintenance. However, a periodic visual inspection of the system would be in order.

The DST should be kept as clean as possible for optimum performance. Dust buildup may be removed from the transducer with a cloth or by low pressure air. The DST housing can be cleaned with soap and water.

If the DST is visibly affected by the environment, a different type of transducer may be required.



### • DCR Specifications

	<b><u>DCR-1005</u></b>	<b><u>DCR-1006</u></b>
Outputs	4 relays (10 A 110 VAC)	4 relays (10 A 110 VAC) with isolated 4-20 mA.
Supply Voltage	24 VDC or 110/220 VAC	24 VDC or 110/220 VAC
Total Current Draw	0.1 A	0.1 A
Housing	Poly-Carbonate	Poly-Carbonate
Rating	NEMA 4X, IP65	NEMA 4X, IP65
Dimensions (in.)	6.25 x 3.125 x 2.25	6.25 x 3.125 x 2.25
Resolution	Maximum of 0.1 in. (2.5mm)	Maximum of 0.1 in. (2.5mm)
Display	4 character digital LCD	4 character digital LCD
24 VDC Output	200 mA current max.	200 mA current max.
Operating Temp	-30 to 60°C	-30 to 60°C
Sample Rate	10 sec to 80 msec.	10 sec to 80 msec.
Adjustments	Programmable modes	Programmable modes
Connector	Terminal Strip	Terminal Strip
Sensor Connector	Coaxial "F" connector or 2-conductor cable	Coaxial "F" connector or 2-conductor cable

• **DST Specifications**

	<b><u>DST-1002</u></b>	<b><u>DST-2421</u></b>
Application	Wet corrosive Environments	Wet corrosive Environments
Operating Range (ft.)	1.5 to 35	1 to 25
Enclosure	PVC	PC/PET
Transducer Type	Ceramic	Ceramic
Transducer Material	PVC	PVDF
Ratings	NEMA 6P/IP65	NEMA 4X
Approvals	Class I, Div. 1	n/a
Operating Temp	-30 to 60°C	-40 to 60°C
Internal Temp Comp.	Yes	Yes
Accuracy	0.25% of range	0.25% of range
Dimensions L x D (in.)	7 x 3.5	7 x 2.5
Beam Pattern	9° off axis	9° off axis
Standard Cable	Coaxial RG-6	2-conductor

• **DST Specifications (continued)**

	<b><u>DST-3431</u></b>	<b><u>DST-5111</u></b>
Application	Wet corrosive Environments	Wet corrosive Environments
Operating Range (ft.)	1.25 to 50	4 to 72 inch
Enclosure	PC/PET	PC/PET
Transducer Type	Ceramic	Ceramic
Transducer Material	PC/PET	PVDF
Ratings	NEMA 4X	NEMA 6P/IP65
Approvals	n/a	n/a
Operating Temp	-40 to 60°C	-30 to 60°C
Internal Temp Comp.	Yes	Yes
Accuracy	0.25% of range	0.25% of range
Dimensions L x D (in.)	7.5 x 3.5	4.5 x 3
Beam Pattern	9° off axis	9° off axis
Standard Cable	2-conductor	2-conductor

• **DST Specifications (continued)**

	<b><u>DST-9421</u></b>
Application	Dry stable Environments
Operating Range (ft.)	0.5 to 35
Enclosure	PC/PET
Transducer Type	Electrostatic
Transducer Material	Gold-Kapton
Ratings	NEMA 12
Approvals	n/a
Operating Temp	-40 to 70°C
Internal Temp Comp.	Yes
Accuracy	0.25% of range
Dimensions L x D (in.)	5.5 x 2.5
Beam Pattern	9° off axis
Cable	2-conductor

**AutoSense SOFTWARE** ~The *AutoSense* software is a built-in feature available with the DST sensor models listed above. It provides automatic sensitivity adjustment and is preferable in tank and level applications. Please use the above part numbers when ordering a DST with the *AutoSense* option.

## Notes

## Notes



## Notes

# AUTOMATION

PRODUCTS  
GROUP, INC.

***APG...Providing tailored solutions  
for measurement applications***



***Automation Products Group, Inc.***

Tel: 1/888/525-7300

1/435/753-7300

Fax: 1/435/753-7490

e-mail: [sales@apgsensors.com](mailto:sales@apgsensors.com)

[www.apgsensors.com](http://www.apgsensors.com)

Automation Products Group, Inc.

1025 W. 1700 N.

Logan, UT 84321