

PT-405

User Manual

Explosion Proof, Heavy Duty Pressure Transmitter

Table of Contents

Introduction	iii
Warranty Statement	iv
Chapter 1: Specifications and Options.....	1
Dimensions	1
Specifications	2
Model Number Configurator.....	3
Electrical Connectors and Pinout Table	4
Chapter 2: Installation and Removal Procedures and Notes.....	5
Tools Needed.....	5
Physical Installation Notes	5
Mounting Instructions	5
Electrical Installation	6
Removal Instructions	6
Chapter 3: Maintenance	7
General Care	7
Zero Trimming.....	7
Re-Calibration.....	8
Repair and Returns.....	8
Chapter 4: Hazardous Location Certification.....	9
CSA Certificate of Compliance	9-16

Introduction

Thank you for purchasing a Series PT-405 Explosion Proof Heavy Duty Pressure Transmitter from APG. We appreciate your business! Please take a few minutes to familiarize yourself with your PT-405 and this manual.

Series PT-405 pressure transmitters offer reliability over a wide range of pressures and in harsh industrial conditions and hazardous locations. It is certified explosion proof for hazardous areas in the US and Canada by CSA for Class 1, Division 1 environments and has a single seal for the highest safety factor. The integrated electronics, wide operating temperature range, and durability make the PT-405 the perfect instrument for static and dynamic pressure measurements with an amplified output signal.

Reading your label

Every APG instrument comes with a label that includes the instrument's model number, part number, serial number, and a wiring pinout table. Please ensure that the part number and pinout table on your label match your order. The following electrical ratings and approvals are also listed on the label. Please refer to the Certificate of Compliance at the back of this manual for further details.

Electrical ratings



Rated: 9 to 28 Volts DC, 4-20mA
Class I Division 1, Groups C and D
T4; $-40^{\circ}\text{C} \leq T_a \leq 85^{\circ}\text{C}$
Single Seal.
Maximum Working Pressure: 30,000 PSI

i **IMPORTANT:** Your PT-405 **MUST** be installed as indicated in Physical Installation Notes (page 5) to meet listed approvals. Faulty installation will invalidate all safety approvals and ratings.

Warranty Statement

This product is covered by APG's warranty to be free from defects in material and workmanship under normal use and service of the product for 24 months. For a full explanation of our Warranty, please visit <https://www.apgsensors.com/about-us/terms-conditions>. Contact Technical Support to receive a Return Material Authorization before shipping your product back.

Scan the QR code below to read the full explanation of our Warranty on your tablet or smartphone.



Chapter 1: Specifications and Options

- Dimensions

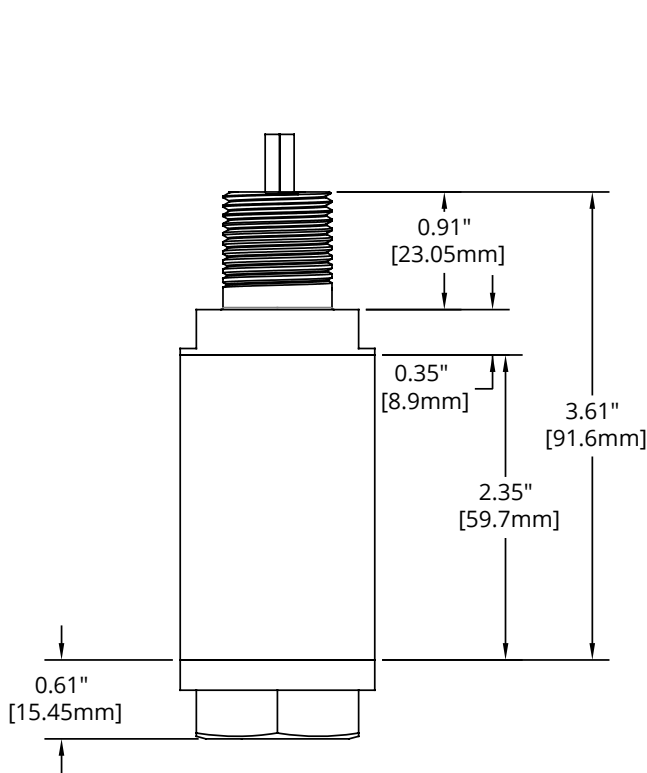

PT-405 Short Can (E60 option)
with female NPT Process connection

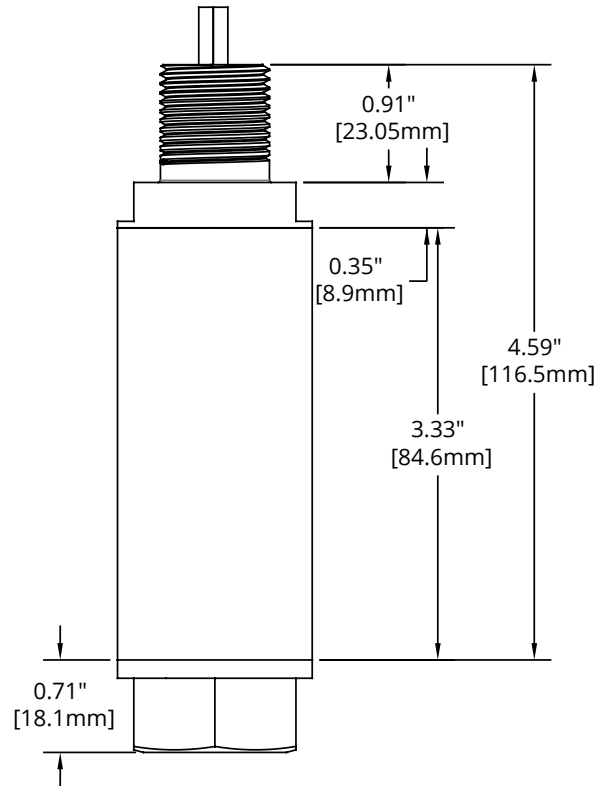

PT-405 Long Can (E60L option)
with female NPT Process Connection

Total length of PT-405 is dependant on Process Connection

• Specifications

Performance

Pressure Ranges	-15 to 30K PSI
Analog Output	4-20mA, 0-5VDC, 0.5-4.5 VDC, 1-5 VDC, 0-10VDC
Digital Output	RS-485/Modbus
Over Pressure	1.5X Full Scale or limit of fitting, whichever is less
Burst Pressure	3.0X Full Scale or limit of fitting, whichever is less

Accuracy

Linearity, Hysteresis & Repeatability	±0.25% of Full Scale (BFSL) (1% for pressure ≤ 1 psi)
Thermal Zero Shift	[±0.036% FSO/°C (±0.02% FSO/°F)]
Thermal Span Shift	[±0.036% FSO/°C (±0.02% FSO/°F)]

Environmental

Operating Temperature	-40 to 85°C / -40 to 185°F
Compensated Temperature	
≤ 10 psi:	0° - 60°C / 32° - 140°F
10 < x ≤ 1000 psi:	-10° - 70°C / 14° - 158°F
> 1000 psi:	-17° - 54°C / 0° - 130°F
Enclosure Protection	IP65

Electrical

Supply Voltage (at sensor)	4-20 mA: 9-28 VDC
	0 to 5 VDC: 9-28 VDC
	0.5 to 4.5 VDC: 9-28 VDC
	1 to 5 VDC: 9-28 VDC
	0 to 10 VDC: 12.5-28 VDC
	RS-485: 9-28 VDC
Output Signal @ 21°C	4-20 mA: 3-30 mA max.
	0 to 5 VDC: 7mA max
	0 to 10 VDC: 14mA max

Materials of Construction

Wetted Materials	316L Stainless Steel (≤ 1,000 psi) 17-4 Stainless Steel (> 1,000 psi) Incoloy (10,000 - 30,000 psi)
Enclosure	316L Stainless Steel

Mechanical

Pressure Connection	See model number configurator for complete list
Weight	408 - 680 g (0.9 - 1.5 lbs.)
Zero & Span Protective Set Screws Torque	28 oz-in

• Model Number Configurator

Model Number: PT-405 - - - - - - - - - - -
A B C D E F G H I J

A. Operation / Output

- L1**[▲] 4 - 20 mA output
- L3** 0 - 5 VDC output
- L10** 0 - 10 VDC output
- L12** 1 - 5 VDC output
- L20** 0.5 - 4.5 VDC output

Modbus

- L5** RS-485 (Modbus/RTU), 4-wire Pressure reading only
- L31** RS-485 (Modbus/RTU), 4-wire Level calculations, tank volume

B. Common Pressure Ranges - PSI*

- | | | | | |
|------------------------------------|-------------------------------------|-------------------------------------|--------------------------------------|---------------------------------------|
| <input type="checkbox"/> 5 | <input type="checkbox"/> 50 | <input type="checkbox"/> 200 | <input type="checkbox"/> 1000 | <input type="checkbox"/> 5000 |
| <input type="checkbox"/> 15 | <input type="checkbox"/> 60 | <input type="checkbox"/> 300 | <input type="checkbox"/> 2000 | <input type="checkbox"/> 10000 |
| <input type="checkbox"/> 30 | <input type="checkbox"/> 100 | <input type="checkbox"/> 500 | <input type="checkbox"/> 3000 | <input type="checkbox"/> 30000 |

*Other ranges available. Please consult factory.

C. Units of Measure

- | | | | | |
|--|-------------------------------------|--|--|--------------------------------------|
| <input type="checkbox"/> psi [▲] | <input type="checkbox"/> bar | <input type="checkbox"/> kPa | <input type="checkbox"/> inH₂O | <input type="checkbox"/> inWC |
| <input type="checkbox"/> fH₂O | <input type="checkbox"/> fWC | <input type="checkbox"/> mmH₂O | <input type="checkbox"/> inHG | |

D. Pressure Type

- A** Absolute (≤ 200 psi)
- S**[▲] Sealed (≤ 30,000 psi)

E. Electrical Connection

- E60** 1/2 in male NPT with flying leads, short cant†
- E60L** 1/2 in male NPT with flying leads, long cant††

† Standard for L1, L3, L10, L12, L20. Not available for L5, L31

†† Standard for L5, L31

▲ This option is standard

F. Electrical Cable Length*

- Number represents length of flying leads in feet
 4-ft length required minimum, 25-ft maximum
 (ex. E60-10 equals short can, 10 ft flying leads)

*Note: All cable must be in conduit.

G. Process Connection

- P0**[▲] 1/4 - 18 male NPT (≤ 10,000 psi)
- P1** 1/2 - 14 male NPT (≤ 10,000 psi)
- P5** 1/4 - 18 female NPT (≤ 15,000 psi)
- P6** 1/2 female NPT (≤ 10,000 psi)
- P38** 1 1/2 in. tri-clover with 3/4 in. diaphragm (≤ 1,000 psi)
- P52** 1 1/2 in. male NPT (≤ 1,000 psi)
- P54** 7/16 - 20 UNJF-3A Male w/ Cone (≤ 1,000 psi)
- P56** F250C High Pressure (10,000 psi - 30,000 psi)
- P57** F562-C40 High Pressure (10,000 psi - 30,000 psi)

H. Accuracy

1 - 5,000 PSI

- N0**[▲] ±0.25% (1% for pressure ≤ 1 psi)
- N1**^{*} ±0.25% with NIST certification
- N2** ±0.1% with NIST certification
- N12** ±0.5% (required for < 500 psi)
- N13** ±0.5% with NIST certification

*Note: ±0.25% available up to 10,000 psi for 4-20 mA output only

Up to 30,000 PSI

- N12** ±0.5%
- N13** ±0.5% with NIST certification

I. Materials

- M1**[▲] 316L SS (≤ 1,000 psi)
- M2** 17-4 SS (> 1000 psi)
- M7** Incoloy (10,000 psi - 30,000 psi; P56/P57 only)

J. Compensated Temperature Range

- S0**[▲] -17° - 54°C / 0° - 130°F (> 1000 psi)
- S1** -40° - 82°C / -40° - 180°F (> 1,000 psi)
- S3** -34° - 77°C / -30° - 170°F (> 1,000 psi)
- S9**[▲] 0° - 60°C / 32° - 140°F (≤ 10 psi)
- S10**[▲] -10° - 70°C / 14° - 158°F (10 < x ≤ 1000 psi)

- **Electrical Connectors, Pinout Table, and Supply Power Table**

PT-405 Series Pin Out Table

	4-20 mA	0-5 / 0.5-4.5 / 1-5 VDC	0-10 VDC	RS-485
Pigtail	Red	+ Excitation	+ Excitation	+ Excitation
	Grn	No wire	+ Output	+ Output
	Wht	No wire	- Output	- Output
	Blk	- Excitation	- Excitation	- Excitation
	Grn/ Ylw	Case Ground	Case Ground	Case Ground

N/C indicates no connection
 For alternate pinouts, please consult factory

PT-405 Series Supply Power Table

	4-20 mA	0-5 / 0.5-4.5 / 1-5 VDC	0-10 VDC	RS-485
Power Supply	9-28 VDC	9-28 VDC	12.5-28 VDC	9-28 VDC

i **IMPORTANT:** Some Modbus manufacturers use reversed Tx+/Tx- pins. When connecting to your system, ensure A to A and B to B connections.

Chapter 2: Installation and Removal Procedures and Notes

• Tools Needed

- Wrench sized appropriately for your PT-405's process connection.
- Thread tape or sealant compound for threaded connections.

• Physical Installation Notes

The PT-405 should be installed in an area--indoors or outdoors--which meets the following conditions:

- Ambient temperature between -40°C and 85°C (-40°F to +185°F)
- Relative humidity up to 100%
- Altitude up to 2000 meters (6560 feet)
- IEC-664-1 Conductive Pollution Degree 1 or 2
- IEC 61010-1 Measurement Category II
- No chemicals corrosive to stainless steel (such as NH₃, SO₂, Cl₂ etc.)
- Ample space for maintenance and inspection
- Explosion proof conduit, with seal installed within 18 inches, must be used for cable connection to PT-405
- Class II power supply

i IMPORTANT: Incorrectly connecting your PT-405 Pressure Transmitter to explosion proof conduit, or using unapproved conduit, will void the protection rating of your PT-405.

• Mounting Instructions

Mounting your pressure transducer is easy if you follow a few simple steps:

- Ensure that the fitting on your sensor matches the fitting on your tank/vessel/pipe/etc. If the fittings do not match, do not attempt to install the sensor. Contact the factory immediately.
- Never over-tighten the sensor. This can compress the diaphragm, changing how it reacts to pressure. In all cases, tighten the sensor as little as possible to create an adequate seal. On straight threads, tighten only until you feel the o-ring compress - making sure you don't damage or extrude the o-ring.
- Always use thread tape or sealant compound on tapered threads. Wrap thread tape in the opposite direction of the threads so it does not unravel as you screw the sensor into place. Unraveling can cause uneven distribution and seal failure. For straight threads, use an o-ring.
- Always start screwing in your sensor by hand to avoid cross-threading. Thread failure can be a problem if you damage threads by over-tightening them or by crossing threads.

- **Electrical Installation**

- Check the pinout table on your PT-405 against your order.
- Check that your electrical system wiring matches the pinout table on your PT-405.
- Connect cable from PT-405 to your control system.

 **DANGER:** Incorrectly connecting your PT-405 Pressure Transmitter to your control system could result in injury or death.

- **Removal Instructions**

Removing your PT-405 from service must be done with care. It's easy to create an unsafe situation, or damage your sensor, if you are not careful to follow these guidelines:

- Make sure the pressure is completely removed from the line or vessel where your sensor is installed. Follow any and all procedures for safely isolating any media contained inside the line or vessel.
- Remove the sensor with an appropriately sized wrench (per your process connection).
- Clean the sensor's fitting and diaphragm of any debris (see General Care) and inspect for damage.
- Store your sensor in a dry place, at a temperature between -40° F and 180° F.

 **DANGER:** Removing your PT-405 Pressure Transmitter while there is still pressure in the line could result in injury or death.

Chapter 3: Maintenance

• General Care

Your PT-405 series pressure transmitter is very low maintenance and will need little care as long as it is installed correctly. However, in general, you should:

- Keep the transmitter and the area around it generally clean.
- Avoid applications for which the transmitter was not designed, such as extreme temperatures, contact with incompatible corrosive chemicals, or other damaging environments.
- Inspect the threads whenever you remove the transmitter from duty or change its location.
- Avoid touching the diaphragm. Contact with the diaphragm, especially with a tool, could permanently shift the output and ruin accuracy.
- Clean the diaphragm or the diaphragm bore with extreme care. If using a tool is required, make sure it does not touch the diaphragm.

• Zero Trimming

- Remove unit from Hazardous Location prior to performing Zero Trimming procedure.
- Remove protective screw(s) with 5/64 allen wrench.
- Ensure that the transmitter is at 0 psig or 0 psia (vacuum if absolute).
- Using a jeweler's screwdriver or a suitable instrument, adjust the "Z" pot until you have a 4 mA, 0 V, 0.5 V, or 1 V output.
- Replace protective screws(s) when finished.

i IMPORTANT: Do not make changes to the Span adjustment (the "S" pot to the right, see Figure 3.1) as part of the zero trimming. The Span should only be changed as part of the recalibration of a gauge with a known pressure source.

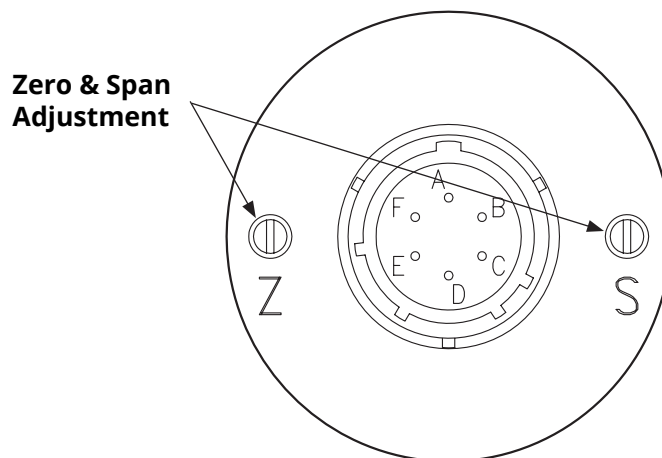

Figure 3.1

DANGER: Protective screws must be replaced using 28 oz-in of torque to create seal.

• Re-Calibration

This procedure requires a known pressure source of at least $\pm 0.1\%$ accuracy in order to fully utilize the accuracy potential of the PT-405. (If not available, you can return it to the factory for re-calibration.)

- Remove unit from Hazardous Location prior to recalibration.
- Ensure that the transducer is at 0 psig or 0 psia (vacuum if absolute), and adjust zero as per instructions for zero trimming.
- Apply full scale pressure to the pressure port and adjust the Span ("S") pot (on the right of Figure 3.1) until the full scale signal is reached.
- Re-check zero and re-adjust the zero ("Z") pot if required.
- Repeat previous two steps until no further adjustment is required.

 NOTE: You may also return the PT-405 to the factory for repair and/or adjustment.

 IMPORTANT: Do not adjust Zero or Span potentiometer while your PT-405 is installed in a Hazardous Location. Removing the protective screws to access the potentiometers invalidates the Hazardous Location approvals until they are replaced.

• Repair and Returns

Should your PT-405 series pressure transmitter require service, please contact the factory via phone, email, or online chat. We will issue you a Return Material Authorization (RMA) number with instructions.

- Phone: 888-525-7300
- Email: sales@apgsensors.com
- Online chat at www.apgsensors.com

Please have your PT-405's part number and serial number available. See Terms & Conditions (<https://www.apgsensors.com/about-us/terms-conditions>) for more information.

Chapter 4: Hazardous Location Installation and Certification

- CSA Certificate of Compliance



Certificate of Compliance

Certificate: 1984045 **Master Contract:** 237484 (237484)
Project: 70159942 **Date Issued:** 2018-03-29
Issued to: Automation Products Group Inc
1025 West 1700 North
Logan, Utah 84321
USA
Attention: Joseph James

The products listed below are eligible to bear the CSA Mark shown with adjacent indicators 'C' and 'US' for Canada and US or with adjacent indicator 'US' for US only or without either indicator for Canada only.



Issued by: *Albert Jansen*
Albert Jansen

PRODUCTS

CLASS 2258 03 - Process Control Equipment - Intrinsically Safe and Non Incendive systems - For Hazardous Locations

CLASS 2258 83 - Process Control Equipment - Intrinsically Safe and Non Incendive systems - For Hazardous Locations - Certified to US Standards

Class I, Div. 2, Groups C and D

Class I, Zone 2, Group IIB

Ex nL IIB T4; -40°C ≤ Ta ≤ +85°C

AEx nC IIB T4; -40°C ≤ Ta ≤ +85°C

- Model PT-400-L1xxxx Pressure Transmitter. Rated 9-28VDC, 4-20mA; Maximum Ambient 85° C; Temperature Code T4; Maximum Working Pressure 10,000 PSI. Enclosure type: IP65. Installed as per Drawing 9002794. Single Seal. Non-Incendive with the following Entity Parameters:

V_{max}, U_i = 28V
I_{max}, I_i = 110mA
P_{max}, P_i = 0.77W
C_i = 0.055µF
L_i = 7.95µH



Certificate: 1984045
Project: 70159942

Master Contract: 237484
Date Issued: 2018-03-29

- Model PT-400-L3/L10xxxx Pressure Transmitter. Rated 9-28VDC, 0-5V, 20mA or 0-10V, 20mA; Maximum Ambient 85° C; Temperature Code T4; Maximum Working Pressure 10,000 PSI. Installed as per Drawing 9002794. Single Seal. Non-Incendive with the following Entity Parameters:

$V_{max}, U_i = 28V$
 $I_{max}, I_i = 110mA$
 $P_{max}, P_i = 0.77W$
 $C_i = 0\mu F$
 $L_i = 0\mu H$

- Model PT-500-xxxx Pressure Transmitter, Rated 10-28VDC, 4-20mA; Maximum Ambient 85° C; Temperature Code T4; Maximum Working Pressure 10,000 PSI; Single Seal. Non-Incendive with the following Entity Parameters:

$V_{max}, U_i = 28V$
 $I_{max}, I_i = 110mA$
 $P_{max}, P_i = 0.77W$
 $C_i = 0\mu F$
 $L_i = 0\mu H$

Conditions of Acceptability: PT-400, PT-500

1. The "x" in the Model designations may be any alpha-numeric character, to denote minor mechanical options, not affecting safety.
2. These devices must be connected to a suitably certified and approved apparatus that provides non-incendive outputs either equal to or less than those as indicated by the applicable control drawings. This certified apparatus must be located in a safe area.
3. The equipment must be connected to a certified class 2 power supply



Certificate: 1984045
Project: 70159942

Master Contract: 237484
Date Issued: 2018-03-29

CLASS 2258 04 - Process Control Equipment - Intrinsically Safe, Entity - For Hazardous Locations
CLASS 2258 84 - Process Control Equipment - Intrinsically Safe, Entity - For Hazardous Locations - Certified to US Standards

Class I, Div. 1, Groups C, D

Class I, Zone 0, Group IIB

Ex ia IIB T4; $-40^{\circ}\text{C} \leq \text{Ta} \leq +85^{\circ}\text{C}$,

AEx ia IIB T4; $-40^{\circ}\text{C} \leq \text{Ta} \leq +85^{\circ}\text{C}$,

- Model PT-400-L1xxxx Pressure Transmitter. Rated 9-28VDC, 4-20mA. Maximum Working Pressure: 10,000 PSI. Installed as per Drawing 9002794. Ambient Range: -40°C to $+85^{\circ}\text{C}$. Enclosure type: IP65. Single Seal. Intrinsically safe with the following entity parameters:

$V_{\text{max}}, U_i = 28\text{V}$
 $I_{\text{max}}, I_i = 110\text{mA}$
 $P_{\text{max}}, P_i = 0.77\text{W}$
 $C_i = 0.055\mu\text{F}$
 $L_i = 7.95\mu\text{H}$

- Model PT-500-xxxx Pressure Transmitter; Maximum Ambient 85°C ; Temperature Code T4; Maximum Working Pressure 10,000 PSI; Single Seal. Entity parameters as follows:

$V_{\text{max}}, U_i = 28\text{V}$
 $I_{\text{max}}, I_i = 110\text{mA}$
 $P_{\text{max}}, P_i = 0.77\text{W}$
 $C_i = 0.042\mu\text{F}$
 $L_i = 0.320\mu\text{H}$

Conditions of Acceptability: PT-400, PT-500

1. The "x" in the Model designations may be any alpha-numeric character, to denote minor mechanical options, not affecting safety.
2. These devices must be connected to a NRTL approved safety barrier (located in a safe area).
3. The equipment must be connected to a certified class 2 power supply



Certificate: 1984045
Project: 70159942

Master Contract: 237484
Date Issued: 2018-03-29

CLASS 2258 02 - Process Control Equipment - For Hazardous Locations
CLASS 2258 82 - Process Control Equipment - For Hazardous Locations - Certified to US Standards

Class I Div. 1 Groups C and D

Model PT-405-xxxxxxxx Pressure Transmitter. Rated 9-28V_{DC}, 4-20mA. Maximum working pressure (MEMS): 1,000 psi). Maximum working pressure (Foil): 30,000psi. Ambient Range: -40°C to +85°C. Single Seal.

Conditions of Acceptability

1. The equipment must be connected to a certified class 2 power supply
2. The conduit connected to the equipment must be sealed within 18 inches of the equipment enclosure.
3. The "x" in the model designation may be any alpha-numeric character, to denote minor mechanical or electrical options, not affecting safety.



Certificate: 1984045
Project: 70159942

Master Contract: 237484
Date Issued: 2018-03-29

APPLICABLE REQUIREMENTS

C22.2 No 0 - M1991	General Requirements - Canadian Electrical Code Part II.
C22.2 No 0.4 - M2004	Bonding and Grounding of Electrical Equipment (Protective Grounding).
C22.2 No. 30 – M1986	Explosion-proof enclosures for use in Class I hazardous locations
C22.2 No 157 - M1992	Intrinsically Safe and Non-Incendive Equipment for Use in Hazardous Locations.
C22.2 No 213 - M1987	Non-Incendive Electrical Equipment for Use in Class I, Division 2 Hazardous Locations.
CAN/CSA-C22.2 No. 60079-0:11	Explosive Atmospheres - Part 0: Equipment - General requirements
CAN/CSA-C22.2 No. 60079-11:11	Explosive Atmospheres – Part 11: Equipment protection by intrinsic safety "i"
CAN/CSA-C22.2 No. 60079-15:12	Electrical apparatus for explosive gas atmospheres - Part 15: Construction, test and marking of type of protection "n" electrical apparatus
CAN/CSA-C22.2 No. 60529:05	Degrees of protection provided by enclosures (IP Code)
CAN/CSA-C22.2 No. 61010-1-12	Safety requirements for electrical equipment for measurement, control, and laboratory use — Part 1: General requirements
UL 508, 17 th Edition	Industrial Control Equipment.
UL 913, 7 th Edition	Intrinsically Safe Apparatus and Associated Apparatus for use in Class I, II, III, Division 1, Hazardous (Classified) Locations.
UL 1203, 5 th Edition	Explosion-Proof and Dust-Ignition-Proof Electrical Equipment for Use in Hazardous (Classified) Locations
UL 61010-1	Electrical Equipment For Measurement, Control, and Laboratory Use; Part 1: General Requirements
ANSI/ISA-12.12.01-2007	Nonincendive Electrical Equipment for Use in Class I and II, Division 2 and Class III, Divisions 1 and 2 Hazardous (Classified) Locations
ANSI/ISA-12.27-01-2003	Requirements for Process Sealing Between Electrical Systems and Flammable or Combustible Process Fluids
ANSI/UL 60079-0:09	Electrical Apparatus for Explosive Gas Atmospheres - Part 0: General Requirements
ANSI/UL 60079-11:09	Electrical apparatus for Explosive Gas Atmospheres - Part 11: Intrinsic Safety "i"
ANSI/UL 60079-15:09	Electrical apparatus for Explosive Gas Atmospheres - Part 15: Type of Protection "n"
ANSI/IEC 60529:2004	Degrees of Protection Provided by Enclosures (IP Code)



Certificate: 1984045
Project: 70159942

Master Contract: 237484
Date Issued: 2018-03-29

MARKINGS

The manufacturer is required to apply the following markings:

- Products shall be marked with the markings specified by the particular product standard.
- Products certified for Canada shall have all Caution and Warning markings in both English and French.

Additional bilingual markings not covered by the product standard(s) may be required by the Authorities Having Jurisdiction. It is the responsibility of the manufacturer to provide and apply these additional markings, where applicable, in accordance with the requirements of those authorities.

The products listed are eligible to bear the CSA Mark shown with adjacent indicators 'C' and 'US' for Canada and US (indicating that products have been manufactured to the requirements of both Canadian and U.S. Standards) or with adjacent indicator 'US' for US only or without either indicator for Canada only.

The following markings must appear on the **PT-400-xxxx** and **PT-500-xxxx** as applicable.

- 1) Submitter's name, trademark, or the CSA file number (adjacent to the CSA Mark).
- 2) Catalogue / Model designation.
- 3) Complete electrical rating (Entity parameters).
- 4) Date code / Serial number traceable to month and year of manufacture.
- 5) Hazardous Location designations.

Class I, Division 2, Groups C and D

Class I, Zone 2, Group IIB

Ex nL IIB T4; $-40^{\circ}\text{C} \leq \text{Ta} \leq +85^{\circ}\text{C}$

AEx nC IIB T4; $-40^{\circ}\text{C} \leq \text{Ta} \leq +85^{\circ}\text{C}$

Class I, Division 1, Groups C,D

Class I, Zone 0, Group IIB

Ex ia IIB T4; $-40^{\circ}\text{C} \leq \text{Ta} \leq +85^{\circ}\text{C}$

AEx ia IIB T4; $-40^{\circ}\text{C} \leq \text{Ta} \leq +85^{\circ}\text{C}$

- 6) The symbol "Ex ia".
- 7) The words "INTRINSICALLY SAFE / SECURITE INTRINSEQUE".
- 8) Temperature code T4
- 9) Maximum ambient 85°C
- 10) The CSA Mark with the "c" and "us" qualifiers.
- 11) Reference to the installation drawings
- 12) The marking "Single Seal"
- 13) The following bilingual cautions: (May be located on the installation drawing)
WARNING: SUBSTITUTION OF COMPONENTS MAY IMPAIR INTRINSIC SAFETY: and,
AVERTISSEMENT: LA SUBSTITUTION DE COMPOSANTS PEUT COMPROMETTRE LA SECURITE INTRINSEQUE".
- 14) The warning: "Must be connected to a Class 2 power supply"

The following markings must appear on the **PT-405-xxxxxxxx** as applicable.

- 1) Submitter's name, trademark, or the CSA file number (adjacent to the CSA Mark).
- 2) Catalogue / Model designation.
- 3) Complete electrical rating
- 4) Date code / Serial number traceable to month and year of manufacture.
- 5) Hazardous Location designations.

Class I, Division 1, Groups C and D

6) Temperature code T4

7) Minimum ambient -40°C , maximum ambient 85°C

8) The CSA Mark with the "c" and "us" qualifiers.

9) Reference to the installation drawings

The marking "Single Seal"



Certificate: 1984045
Project: 70159942

Master Contract: 237484
Date Issued: 2018-03-29

10) The warnings

1. EXPLOSION HAZARD – ENSURE SET SCREWS ARE FULLY TIGHTENED, AND DO NOT DISCONNECT OR CALIBRATE EQUIPMENT, UNLESS POWER HAS BEEN SWITCHED OFF OR AREA IS KNOWN TO BE NON-HAZARDOUS.
2. SEAL WITHIN 18”
3. Must be connected to a Class 2 power supply



Certificate: 1984045
Project: 70159942

Master Contract: 237484
Date Issued: 2018-03-29

Supplement to Certificate of Compliance

Certificate: 1984045

Master Contract: 237484 (237484)

The products listed, including the latest revision described below, are eligible to be marked in accordance with the referenced Certificate.

Product Certification History

Project	Date	Description
70159942	2018-03-29	Update CSA 142 to 61010 3rd Ed. 2. Add new explosionproof model PT-405 for Class I, Division 1, Groups C&D. Add "Single Seal" marking to PT-400, PT-405, and PT-500.
2587208	2012-12-17	Update to include revised documentation.
2517306	2012-08-22	Update to include revised schematics for the PT400-L1xxxx pressure sensor.
1984045	2008-03-04	PT-400 and PT-500 Pressure Transducers for use in Hazardous Locations as Intrinsically Safe and Non-Incendive



Automation Products Group, Inc.

Tel: 1/888/525-7300 • Fax: 1/435/753-7490 • www.apgsensors.com • sales@apgsensors.com