

# **PT-500 Modbus Series User Manual**

# Table of Contents

<b>Introduction</b> .....	<b>iii</b>
<b>Warranty and Warranty Restrictions</b> .....	<b>iv</b>
<b>Chapter 1: Specifications and Options</b> .....	<b>1</b>
Dimensions .....	1
Specifications .....	2
Model Number Configurator.....	3
Electrical Pinout Table, Power Supply Table, and System Wiring Diagrams.....	4
<b>Chapter 2: Installation and Removal Procedures and Notes</b> .....	<b>5</b>
Tools Needed.....	5
Mounting Instructions .....	5
Electrical Installation .....	5
Removal Instructions .....	6
<b>Chapter 3: Programming</b> .....	<b>6</b>
Modbus Programming .....	6
Modbus Programming with RST-6001 and APG Modbus Software .....	6
PT-500 Modbus Register Lists .....	7-9
PT-500 Modbus Sensor Parameters - L5 pressure series.....	10
PT-500 Modbus Sensor Parameters - L31 level series .....	10
PT-500 Modbus Application Parameters - L31 level series .....	11-15
<b>Chapter 4: Maintenance</b> .....	<b>16</b>
General Care .....	16
Vent Tube Drying.....	16-17
Repair and Returns.....	17

 **NOTE:** Wiring information in this User Manual is specific to the Modbus Series of the PT-500. If you have a 0-5V, mV/V, or 4-20 mA Series sensor, please consult the factory at 1-888-525-7300, or our website at [www.apgsensors.com/support](http://www.apgsensors.com/support), for the appropriate manual for your sensor.

# Introduction

Thank you for purchasing a PT-500 modbus series submersible pressure transmitter from APG. We appreciate your business! Please take a few minutes to familiarize yourself with your PT-500 and this manual.

PT-500 submersible pressure transmitters offer reliability in harsh industrial conditions. The small size, integrated electronics, wide operating temperature range, and durability make the PT-500 the perfect instrument for static and dynamic pressure measurement.

## Reading your label

Every APG instrument comes with a label that includes the instrument's model number, part number, serial number, and a wiring pinout table. Please ensure that the part number and pinout table on your label match your order.

# Warranty and Warranty Restrictions

This product is covered by APG's warranty to be free from defects in material and workmanship under normal use and service of the product for 24 months. For a full explanation of our Warranty, please visit <https://www.apgsensors.com/about-us/terms-conditions>. Contact Technical Support to receive a Return Material Authorization before shipping your product back.

Scan the QR code below to read the full explanation of our Warranty on your tablet or smartphone.



# Chapter 1: Specifications and Options

- Dimensions

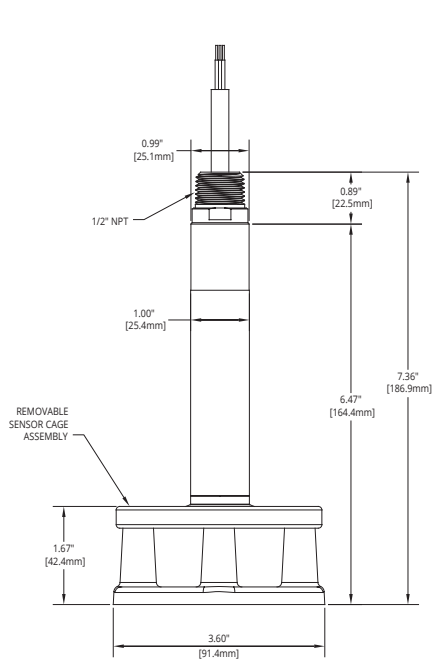

PT-500 with Reusable Cage

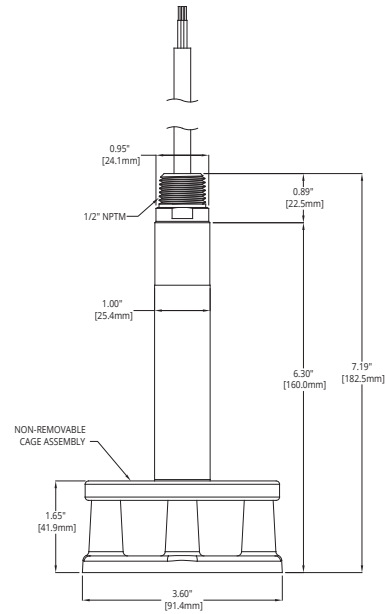

PT-500 with Welded Anti-sag Cage

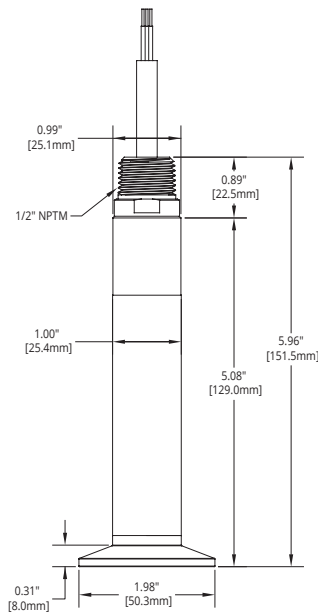

PT-500 with Tri-clover Sanitary Fitting

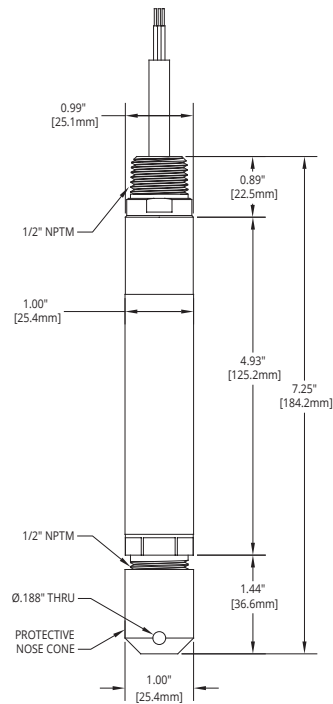

PT-500 with Removable Plastic Nose Cone

## • Specifications

### Performance

Pressure Ranges	0 to 250 PSI
Digital Output	Modbus RTU, 4-wire RS-485
Over Pressure	2X FSO
Burst Pressure	3.0X FSO
1 Year Stability	0.75% FSO

### Accuracy

Linearity, Hystereses & Repeatability	±0.25% of Full Scale (BFSL) up to ±0.1% of Full Scale ±1.0% for ≤ 1 psi
Thermal Zero Shift @ 70 °F	±0.045% FSO/°C (±0.025% FSO/°F)
Thermal Span Shift @ 70 °F	±0.045% FSO/°C (±0.025% FSO/°F)

### Environmental

Operating Temperature	-40 to 85°C / -40 to 185°F
Compensated Temperature	
≤ 10 psi:	0° - 60°C / 32° - 140°F
> 10 psi:	-10° - 70°C / 14° - 158°F
Maximum Submersible Depth	575 ft / 175.25 m / 250 psi

### Electrical

Supply Voltage (at sensor)	5-28 VDC
Current Draw	2 mA max.
Protection	Reverse Polarity and Surge (per IEC 61000-4-5)
Load Limitation	$R_{(max)} = ((V_s - 12V) / 0.02A) - (0.042\Omega \text{ per ft. of cable})$
Startup Time	200 ms

### Materials of Construction

Wetted Materials	316L Stainless Steel
Anti-snag Cage	316L Stainless Steel
Cable	Urethane, PVC, or Hytrel
Protective Nose Cone	Delrin
Seal	Viton ETP-s

### Mechanical

Pressure Connection	See model number configurator for complete list
Cable Tensile Strength	Up to 200 pounds

### Patents

US Patent No. 7,787,330



- **Electrical Pinout Table, Supply Power Table, and System Wiring Diagrams**

**PT-500 Modbus Series Pinout Table**

Pigtail		<b>Modbus</b>
	Red	+ Power
	Black	- Power
	Green	B (TX-)
	White	A (TX+)
Shield Drain	Case Gnd	

**PT-500 Modbus Series Supply Power Table**

	<b>Modbus</b>
Power Supply	5-28 Vdc

Note: Either transducer case OR shield drain wire must be physically connected to low-impedance earth ground.

**Modbus System Wiring**

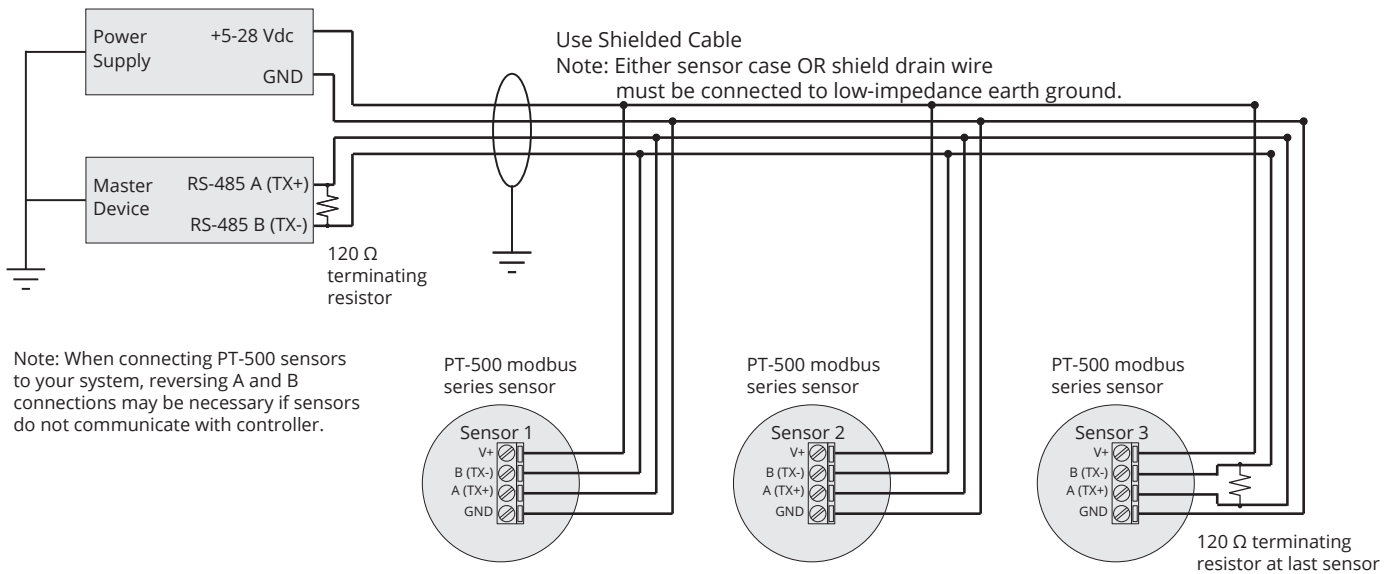

**Modbus System Wiring with RST-6001**

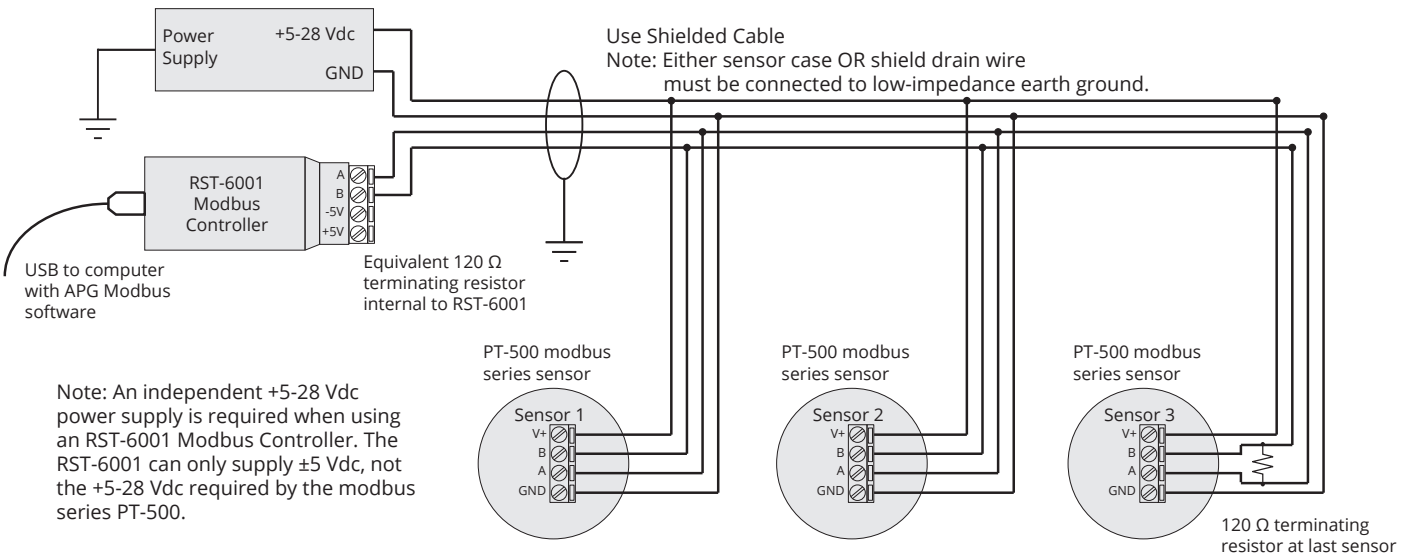



# Chapter 2: Installation and Removal Procedures and Notes

- **Tools Needed**

- Wrench sized appropriately for your PT-500's process or conduit connection.
- Thread tape or sealant compound for threaded connections.

- **Mounting Instructions**

Your PT-500 can be mounted in three ways: via NPT process connection, free-hanging suspension, or conduit mounted. Mounting your pressure transducer is easy if you follow a few simple steps:

- Never over-tighten the sensor. In all cases, tighten the sensor as little as possible to create an adequate seal.
- Always use thread tape or sealant compound on tapered threads. Wrap thread tape in the opposite direction of the threads so it does not unravel as you screw the sensor into place. Unraveling can cause uneven distribution and seal failure.
- Always start screwing in your sensor by hand to avoid cross-threading. Thread failure can be a problem if you damage threads by over-tightening them or by crossing threads.
- For suspension mounting the PT-500, drill a 3/16" hole into the 1/2" NPTF to 1/2" NPTF hex coupler (P/N 511414) and secure it to the 1/2" NPTM coupler fitting of the PT-500. Attach a .060" diameter 316L SS cable of desired length to the hex coupler and secure the steel cable according to your application requirements.

 **NOTE:** If your PT-500 has a vent tube, do not seal, cover, or close the vent tube with anything other than an APG-provided venting cap or desiccant drying cartridge (See Figure 4.1 and 4.2). Unapproved seals or covers will prevent proper sensor operation.

- **Electrical Installation**

- Attach the wires of your PT-500 to your control system according to the pinout table above.

 **IMPORTANT:** Some manufacturer's Modbus equipment uses reversed TX+/TX- pins. When making connections between APG equipment, reversing connections may be necessary if sensor does not communicate with controller.

 **IMPORTANT:** For lightning transient/surge protection to be effective, either PT-500 case OR shield drain wire must be physically connected to low-impedance earth ground.

## • Removal Instructions

Removing your PT-500 from service must be done with care. It's easy to create an unsafe situation, or damage your sensor, if you are not careful to follow these guidelines:

- For sensors installed via NPT process connection, make sure the pressure is completely removed from the line or vessel. Follow any and all procedures for safely isolating any media contained inside the line or vessel.
- Remove the sensor with an appropriately sized wrench (per your process connection).
- For suspended sensors, retrieve the sensor from the vessel. Follow any and all procedures for safely isolating any media contained inside the line or vessel.
- Carefully clean the sensor's fitting and diaphragm of any debris (see General Care) and inspect for damage.
- Store your sensor in a dry place, at a temperature between -40° F and 180° F.

 **DANGER:** Removing your process connected PT-500 Pressure Transmitter while there is still pressure in the line could result in injury or death.

 **IMPORTANT:** Any contact with the diaphragm can permanently damage the sensor. Use extreme caution.

## Chapter 3: Programming

### • Modbus Programming

PT-500 L5/L31 modbus series sensors use standard Modbus RTU protocol (RS-485). The sensors can only operate as slave devices. Sensor default transmission settings are **9600 Baud, 8 Bits, 1 Stop Bit, No Parity**, and require a minimum delay of 300 ms between transactions to return the contents of all registers. Commands returning fewer registers will require shorter delays. See PT-500 Modbus Register Lists on pages 7 - 9.

 **NOTE:** For more information about Modbus RTU, please visit [www.modbus.org](http://www.modbus.org).

- **Modbus Programming with RST-6001 and APG Modbus Software**

APG RST-6001 Modbus Controller can be used in tandem with APG Modbus to program and control up to 20 PT-500 L5 or PT-500 L31 sensors. Through APG Modbus, you can monitor the raw readings from the sensor, including level or pressure, temperature and battery voltage, or configure the sensor. See PT-500 Modbus Register Lists on pages 7 - 9.

 **NOTE:** For APG Modbus programming instructions, or to download APG Modbus software, please visit [www.apgsensors.com/support](http://www.apgsensors.com/support).

- **PT-500 Modbus Register Lists**

**Input Registers (0x04)**

<b>Register</b>	<b>Returned Data</b>
30299	Model Type
30300	Pressure (L5 - PSI; L31 - mmH <sub>2</sub> O)
30301	N/A
30302	Temperature Reading (in °C, signed)
30303-30304	Calculated (raw)
30305-30306	N/A
30307	N/A
30308	Battery Voltage
30309	Trip 1 Status
30310	Trip 2 Status

 **NOTE:** The Calculated Readings will be returned without a decimal place. In order to obtain the true result, the Decimal Place setting must be taken into account.

## Holding Registers (0x03) - PT-500 L5 pressure series

<u>Register</u>	<u>Function</u>	<u>Value Range</u>
40400	Device Address	1 to 247
40401	Units	0-16
40402	Application Type	0 or 8
40403	N/A	
40404	Decimal (Calculated)	0 - 3
40405	Max Pressure	*0 - 32,000 PSI
40406	Full Pressure	0 - 32,000 PSI
40407	Zero Offset	-15,000 - 30,000 PSI
40408	Pressure Decimal	0 - 3
40409	A/D Gain	*1, 2, 4, 8, 16, 32, 64, 128
40410	N/A	
40411	Parameter Default	0 = No; 1 = Restore Defaults
40412	Averaging	0 - 10
40413	Calibration Value	*-32,767 - 32,767
40414	Calibration Flag	*0 - 300
40415	Sample Rate	10 to 1000 milliseconds
40416	Scale	*0 - 65,535
40417	Offset	-20,000 - 20,000
40418	Voltage Offset	-20 - 20
40419	Baud Rate	0 - 3 (2400, 9600, 19200)
40420	Parity	0 - 2 (none, even, odd)
40421	Stop Bit	0 - 1 (0 = 1 stop bit; 1 = 2 stop bits)
40422-40423	Pressure X <sup>3</sup>	*N/A
40424-40425	Pressure X <sup>2</sup>	*N/A
40426-40427	Pressure X <sup>1</sup>	*N/A
40428-40429	Pressure X <sup>0</sup>	*N/A
40430	Trip 1 Pressure	-15,000 - 30,000 PSI
40431	Trip 1 Window	0 - 30,00 PSI
40432	Trip 1 Type	0 - 29
40433	Trip 2 Pressure	-15,000 - 30,000 PSI
40434	Trip 2 Window	0 - 30,00 PSI
40435	Trip 2 Type	0 - 29
40436-40437	Multiplier	0.0010 - 99.9999 (float)
40438-40439	Description	A - Z, 0 - 9, /, ., +* (16 char)
40446	Temperature Offset	-20 - 20
40447-40448	Temperature X <sup>3</sup>	*N/A
40449-40450	Temperature X <sup>2</sup>	*N/A
40451-40452	Temperature X <sup>1</sup>	*N/A
40453-40454	Temperature X <sup>0</sup>	*N/A

\*Setting is factory calibrated. Do not adjust.

## Holding Registers (0x03) - PT-500 L31 level series

<u>Register</u>	<u>Function</u>	<u>Value Range</u>
40400	Device Address	1 to 247
40401	Units	1 = Feet, 2 = Inches, 3 = Meters
40402	Application Type	0 - 11
40403	Volume Units	1 - 7
40404	Decimal (Calculated)	0 - 3
40405	Max Level	*0 - 65,535 mm
40406	Full Level	0 - 65,535 mm
40407	Zero Offset	0 - 610 mm
40408	N/A	
40409	A/D Gain	*1, 2, 4, 8, 16, 32, 64, 128
40410	Specific Gravity	1 - 2,000
40411	Parameter Default	0 = No; 1 = Restore Defaults
40412	Averaging	0 - 10
40413	Calibration Value	*0 - 65,535
40414	Calibration Flag	*0 - 300
40415	Sample Rate	10 to 1000 milliseconds
40416	Scale	*0 - 65,535
40417	Offset	-20,000 - 20,000
40418	Voltage Offset	-20 - 20
40419	Baud Rate	0 - 3 (2400, 9600, 19200)
40420	Parity	0 - 2 (none, even, odd)
40421	Stop Bit	0 - 1 (0 = 1 stop bit; 1 = 2 stop bits)
40422-40423	Pressure X <sup>3</sup>	*N/A
40424-40425	Pressure X <sup>2</sup>	*N/A
40426-40427	Pressure X <sup>1</sup>	*N/A
40428-40429	Pressure X <sup>0</sup>	*N/A
40430	Trip 1 Level	0 - 65,535 (mm)
40431	Trip 1 Window	0 - 65,535 (mm)
40432	Trip 1 Type	0 - 29
40433	Trip 2 Level	0 - 65,535 (mm)
40434	Trip 2 Window	0 - 65,535 (mm)
40435	Trip 2 Type	0 - 29
40436-40437	Parameter 1	0 - 1,000,000 (mm)
40438-40439	Parameter 2	0 - 1,000,000 (mm)
40440-40441	Parameter 3	0 - 1,000,000 (mm)
40442-40443	Parameter 4	0 - 1,000,000 (mm)
40444-40445	Parameter 5	0 - 1,000,000 (mm)
40446	Temperature Offset	-20 - 20
40447-40448	Temperature X <sup>3</sup>	*N/A
40449-40450	Temperature X <sup>2</sup>	*N/A
40451-40452	Temperature X <sup>1</sup>	*N/A
40453-40454	Temperature X <sup>0</sup>	*N/A

\*Setting is factory calibrated. Do not adjust.

## • PT-500 Modbus Sensor Parameters - L5 pressure series

### 40401 - Units

Determines the units of measure for the calculated reading.

0 = PSI	5 = mmH2O <sup>†</sup>	10 = mmHG <sup>‡</sup>	14 = inSW
1 = BAR	6 = cmH2O <sup>†</sup>	11 = cmHG <sup>‡</sup>	15 = ftSW
2 = mBAR	7 = mH2O <sup>†</sup>	12 = inHG <sup>‡</sup>	16 = mSW
3 = kPa	8 = inH2O <sup>†</sup>	13 = kg/cm <sup>2</sup>	
4 = MPa	9 = ftH2O <sup>†</sup>		

<sup>†</sup> All H2O pressure measurements @ 20° C.

<sup>‡</sup> All HG pressure measurements @ 0° C.

### 40402 - Application Type

Determines the units of measure for the calculated reading.

0 = Standard (units selected in 40401 are displayed)

8 = Custom (units selected in 40401 and multiplier in 40436-40437 are used to compute desired units; description in 40438-40439 is label for measurement)

## • PT-500 Modbus Sensor Parameters - L31 level series

### 40401 - Units

Determines the units of measure for the calculated reading when Application Type is set to 0, 1, or 7.

1 = Feet	2 = Inches	3 = Meters
----------	------------	------------

### 40402 - Application Type

Determines the type of calculated reading performed by the sensor.

0 = Distance

1 = Level

2 = Standing Cylindrical Tank with or without Hemispherical Bottom

3 = Standing Cylindrical Tank with or without Conical Bottom

4 = Standing Rectangular Tank with or without Chute Bottom

5 = Horizontal Cylindrical Tank with or without Spherical Ends

6 = Spherical Tank

7 = Pounds (Linear Scaling)

8 = N/A

9 = Vertical Oval Tank

10 = Horizontal Oval Tank

11 = Strapping Chart

## 40403 - Volume Units

Determines the units of measure for the calculated reading when Application Type is set to 2 - 6 or 9 -11.

1 = Feet <sup>3</sup>	5 = Liters
2 = Million Feet <sup>3</sup>	6 = Inches <sup>3</sup>
3 = Gallons	7 = Barrels
4 = Meters <sup>3</sup>	

## • PT-500 Modbus Application Parameters - L31 level series

### Application 0 - Distance

<u>Register</u>	<u>Function</u>	<u>Value Range</u>
40400	Device Address	1 to 247
40401	Units	1 = Feet, 2 = Inches, 3 = Meters
40402	Application Type	0
40403	Volume Units	--
40404	Decimal (Calculated)	0 - 3

### Application 1 - Level

<u>Register</u>	<u>Function</u>	<u>Value Range</u>
40400	Device Address	1 to 247
40401	Units	1 = Feet, 2 = Inches, 3 = Meters
40402	Application Type	1
40403	Volume Units	--
40404	Decimal (Calculated)	0 - 3

### Application 2 - Volume of Standing Cylindrical Tank ± Hemispherical Bottom

<u>Register</u>	<u>Function</u>	<u>Value Range</u>
40400	Device Address	1 to 247
40401	Units	--
40402	Application Type	2
40403	Volume Units	1 - 7
40404	Decimal (Calculated)	0 - 3
40405	Max Level	(factory set)
40406	Full Level	0 - 65,535 mm
40436-40437	Tank Diameter	0 - 1,000,000 (mm)
40438-40439	Radius of Bottom Hemisphere	0 - 1,000,000 (mm)

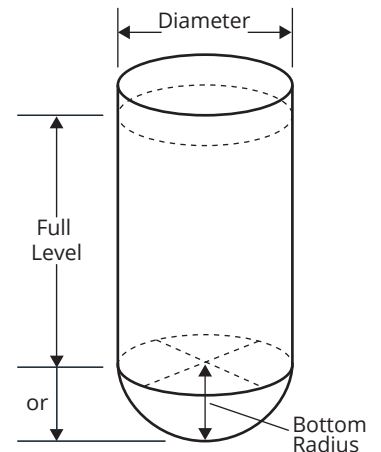

### Application 3 - Volume of Standing Cylindrical Tank ± Conical Bottom

<b>Register</b>	<b>Function</b>	<b>Value Range</b>
40400	Device Address	1 to 247
40401	Units	--
40402	Application Type	3
40403	Volume Units	1 - 7
40404	Decimal (Calculated)	0 - 3
40405	Max Level	(factory set)
40406	Full Level	0 - 65,535 mm
40436-40437	Tank Diameter	0 - 1,000,000 (mm)
40438-40439	Cone Diameter (at bottom of cone)	0 - 1,000,000 (mm)
40440-40441	Length (height) of Cone	0 - 1,000,000 (mm)

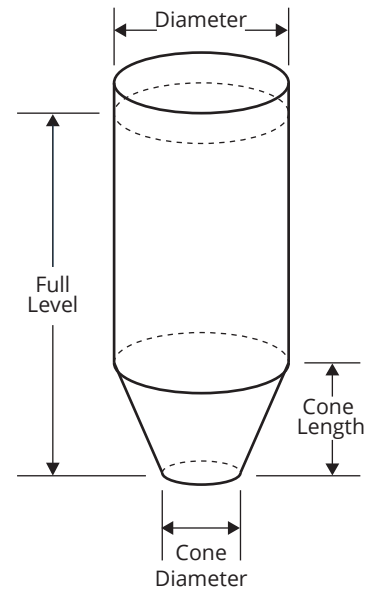

### Application 4 - Volume of Standing Rectangular Tank ± Chute Bottom

<b>Register</b>	<b>Function</b>	<b>Value Range</b>
40400	Device Address	1 to 247
40401	Units	--
40402	Application Type	4
40403	Volume Units	1 - 7
40404	Decimal (Calculated)	0 - 3
40405	Max Level	(factory set)
40406	Full Level	0 - 65,535 mm
40436-40437	Tank X Dimension	0 - 1,000,000 (mm)
40438-40439	Tank Y Dimension	0 - 1,000,000 (mm)
40440-40441	Chute X Dimension	0 - 1,000,000 (mm)
40442-40443	Chute Y Dimension	0 - 1,000,000 (mm)
40444-40445	Length (height) of Chute	0 - 1,000,000 (mm)

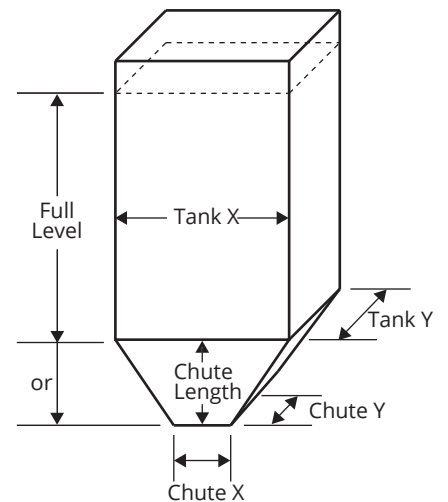



## Application 5 - Volume of Horizontal Cylindrical Tank ± Hemispherical Ends

<b>Register</b>	<b>Function</b>	<b>Value Range</b>
40400	Device Address	1 to 247
40401	Units	--
40402	Application Type	5
40403	Volume Units	1 - 7
40404	Decimal (Calculated)	0 - 3
40405	Max Level	(factory set)
40406	Full Level	0 - 65,535 mm
40436-40437	Tank Length	0 - 1,000,000 (mm)
40438-40439	Tank Diameter	0 - 1,000,000 (mm)
40440-40441	Radius of End Hemispheres	0 - 1,000,000 (mm)

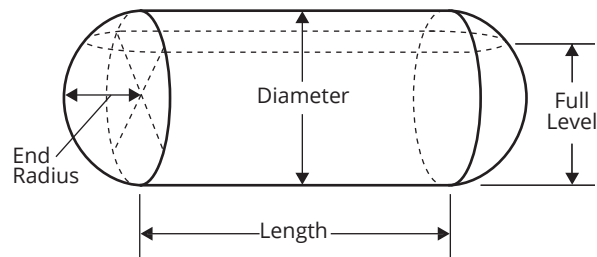

## Application 6 - Volume of Spherical Tank

<b>Register</b>	<b>Function</b>	<b>Value Range</b>
40400	Device Address	1 to 247
40401	Units	--
40402	Application Type	6
40403	Volume Units	1 - 7
40404	Decimal (Calculated)	0 - 3
40405	Max Level	(factory set)
40406	Full Level	0 - 65,535 mm
40436-40437	Tank Diameter	0 - 1,000,000 (mm)

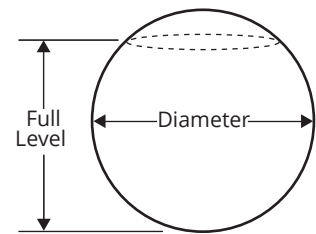

## Application 7 - Pounds (Linear Scaling)

<b>Register</b>	<b>Function</b>	<b>Value Range</b>
40400	Device Address	1 to 247
40401	Units	1 = Feet, 2 = Inches, 3 = Meters
40402	Application Type	7
40403	Volume Units	--
40404	Decimal (Calculated)	0 - 3
40405	Max Level	(factory set)
40406	Full Level	0 - 65,535 mm
40436-40437	Multiplier (linear scalar)	0 - 1,000,000 (1000 = 1.000)

## Application 9 - Volume of Vertical Oval Tank

<b>Register</b>	<b>Function</b>	<b>Value Range</b>
40400	Device Address	1 to 247
40401	Units	--
40402	Application Type	9
40403	Volume Units	1 - 7
40404	Decimal (Calculated)	0 - 3
40405	Max Level	(factory set)
40406	Full Level	0 - 65,535 mm
40436-40437	Tank Length	0 - 1,000,000 (mm)
40438-40439	Tank Depth	0 - 1,000,000 (mm)
40440-40441	Tank Width	0 - 1,000,000 (mm)

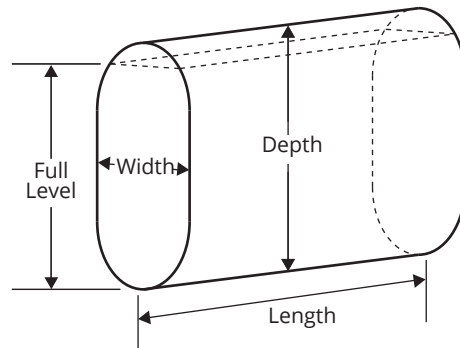

## Application 10 - Volume of Horizontal Oval Tank

<u>Register</u>	<u>Function</u>	<u>Value Range</u>
40400	Device Address	1 to 247
40401	Units	--
40402	Application Type	10
40403	Volume Units	1 - 7
40404	Decimal (Calculated)	0 - 3
40405	Max Level	(factory set)
40406	Full Level	0 - 65,535 mm
40436-40437	Tank Length	0 - 1,000,000 (mm)
40438-40439	Tank Depth	0 - 1,000,000 (mm)
40440-40441	Tank Width	0 - 1,000,000 (mm)

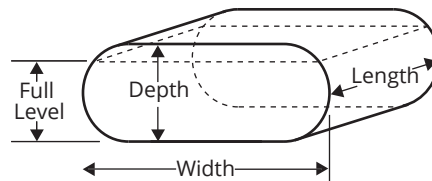

## Application 11 - Strapping Chart (Polynomial Values)

<u>Register</u>	<u>Function</u>	<u>Value Range</u>
40400	Device Address	1 to 247
40401	Units	1 = Feet, 2 = Inches, 3 = Meters
40402	Application Type	11
40403	Volume Units	1 - 7
40404	Decimal (Calculated)	0 - 3
40405	Max Level	(factory set)
40406	Full Level	0 - 65,535 mm
40436-40437	X <sup>3</sup> Coefficient	0 - 1,000,000
40438-40439	X <sup>2</sup> Coefficient	0 - 1,000,000
40440-40441	X <sup>1</sup> Coefficient	0 - 1,000,000
40442-40443	X <sup>0</sup> Coefficient	0 - 1,000,000

# Chapter 4: Maintenance

## • General Care

Your PT-500 series pressure transmitter is very low maintenance and will need little care as long as it is installed correctly. However, in general, you should:

- For process connected sensors, keep the transmitter and the area around it generally clean.
- Avoid applications for which the transmitter was not designed, such as extreme temperatures, contact with incompatible corrosive chemicals, or other damaging environments.
- Inspect the threads whenever you remove the transmitter from duty or change its location.
- Avoid touching the diaphragm. Contact with the diaphragm, especially with a tool, could permanently shift the output and ruin accuracy.
- Clean the diaphragm or the diaphragm bore with extreme care. If using a tool is required, make sure it does not touch the diaphragm.

**i** IMPORTANT: Any contact with the diaphragm can permanently damage the sensor. Use extreme caution.

## • Vent Tube Drying

Condensation in the vent tube can damage the electronics in your sensor, resulting in unreliable readings. APG offers two methods of preventing vent tube condensation: a venting cap, and a desiccant drying cartridge.

The venting cap is a PVC tube with a hydrophobic patch that allows moisture to pass out of the tube without allowing water in (See Figure 4.1). The cap is sealed by an o-ring, and is easily installed in the field.

The desiccant drying cartridge with vent tube adapter absorbs any moisture in the vent tube to keep vapor from condensing (See Figure 4.2). The installation of the desiccant drying cartridge is quick and easy. Common installation methods are cable tie, Velcro, and cable clamps.

**i** IMPORTANT: Do NOT use desiccant cartridge in the presence of vapors or liquids containing phosphate esters, synthetic lubricants, hydrocarbon solvents, methanol, acetone, lacquer solvents, or other organics.



Figure 4.1



Figure 4.2

 NOTE: Desiccant crystals change from blue to pink as they become saturated. Cartridge must be replaced when all crystals have saturated.

## • Repair and Returns

Should your PT-500 series pressure transmitter require service, please contact the factory via phone, email, or online chat. We will issue you a Return Material Authorization (RMA) number with instructions.

- Phone: 888-525-7300
- Email: [sales@apgsensors.com](mailto:sales@apgsensors.com)
- Online chat at [www.apgsensors.com](http://www.apgsensors.com)

Please have your PT-500's part number and serial number available. See Warranty and Warranty Restrictions for more information.



**Automation Products Group, Inc.**

Tel: 1/888/525-7300 • Fax: 1/435/753-7490 • [www.apgsensors.com](http://www.apgsensors.com) • [sales@apgsensors.com](mailto:sales@apgsensors.com)