

PT-510 and PT-510W Series User Manual

4-20 mA

Table of Contents

Introduction	iii
Warranty and Warranty Restrictions	iv
Chapter 1: Specifications and Options.....	1
Dimensions	1
Specifications	2
Model Number Configurator.....	3-4
Electrical Pinout Table and Supply Power Table.....	5
Chapter 2: Installation and Removal Procedures and Notes.....	5
Tools Needed.....	5
Mounting Instructions	5
Electrical Installation	5
Removal Instructions	6
Chapter 3: Maintenance	6
General Care	6
Vent Tube Drying.....	7
Repair and Returns.....	8

Introduction

Thank you for purchasing a PT-510/PT-510W series submersible pressure transmitter from APG. We appreciate your business! Please take a few minutes to familiarize yourself with your PT-510 and this manual.

PT-510/PT-510W series submersible pressure transmitters offer reliability in harsh industrial conditions. The small size, and all welded, all stainless steel body make the durable PT-510/PT-510W the perfect instrument for static and dynamic pressure measurement. The PT-510 comes with a Delrin nose cone, suitable for clean water use, while the PT-510W has a stainless steel cage for additional transducer protection in wastewater environments.

Reading your label

Every APG instrument comes with a label that includes the instrument's model number, part number, serial number, and a wiring pinout table. Please ensure that the part number and pinout table on your label match your order.

Warranty and Warranty Restrictions

This product is covered by APG's warranty to be free from defects in material and workmanship under normal use and service of the product for 24 months. For a full explanation of our Warranty, please visit <https://www.apgsensors.com/about-us/terms-conditions>. Contact Technical Support to receive a Return Material Authorization before shipping your product back.

Scan the QR code below to read the full explanation of our Warranty on your tablet or smartphone.



Chapter 1: Specifications and Options

- Dimensions

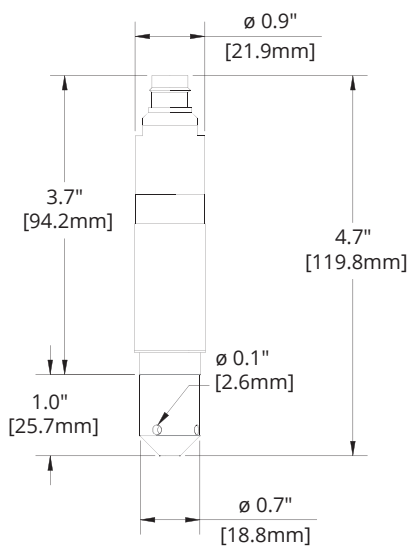

PT-510 with Removable Plastic
Nose Cone

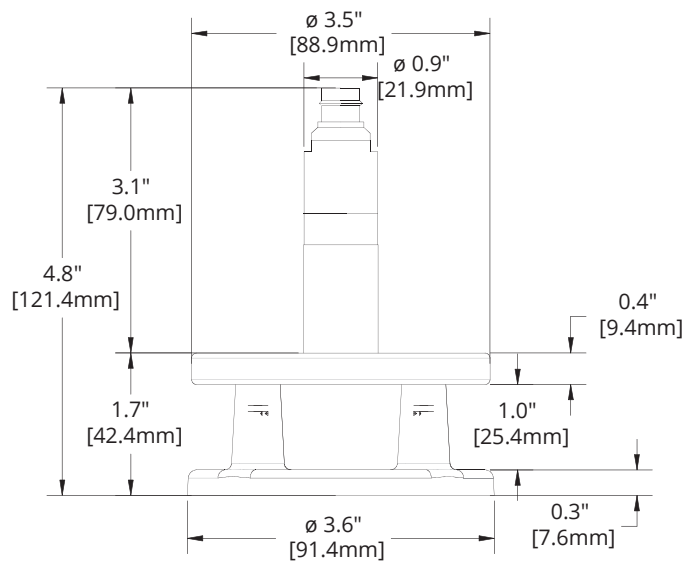

PT-510W with Welded Cage

• Specifications

Performance

Pressure Ranges	0 to 20 PSIG
Analog Output	4-20mA
Over Pressure	2X FS
Burst Pressure	3X FS

Accuracy

Overall	±0.5% of Full Scale (BFSL)
Linearity	±0.25% of Full Scale (BFSL)
Hysteresis	±0.15% of Full Scale
Repeatability	±0.20% of Full Scale
Span	±1% of Full Scale
Zero	±1% of Full Scale

Environmental

Operating Temperature	-4 to 185°F (-20 to 85°C)
Maximum Submersible Depth	46 ft / 14 m / 20 psig

Electrical

Supply Voltage (at sensor)	11-30 VDC
Current Draw	3-30 mA

Materials of Construction

Wetted Materials	18-8 Stainless Steel, Stycast
Cable	PVC, Hytrel, or Polyurethane
Seal	Neoprene Rubber
Nose Cone (PT-510 only)	PVC
Cage (PT-510W only)	18-8 Stainless steel

Mechanical

Cable Tensile Strength	Up to 200 pounds
------------------------	------------------

Part Number: PT-510W - - - -
 A B C D

A. Cable Type

- B** Hytrel 0.31" Ø - Black (with vent tube)
- C▲** PVC - Black (with vent tube)
- E** Polyurethane - Black (with vent tube)

B. Pressure Range - PSI

- 5**
- 10**
- 15**
- 20**

C. Output

- L01▲** 4-20 mA, 2-wire (+ ground)

D. Cable Length

- XXX** (specify length of cable needed in feet)
- 040▲** 40 foot length standard for 5 & 10 PSI
- 060▲** 60 foot length standard for 15 & 20 PSI

Note: ▲ Indicates this option is standard.

- **Electrical Pinout Table and Supply Power Table**

PT-510/PT-510W Series Pin Out Table

Pigtail	4-20 mA	
	Red	+ Power/Signal
	White	- Power/Signal
	Green	Case Gnd

PT-510/PT-510W Series Supply Power Table

4-20 mA	
Power Supply	11-30 VDC

Chapter 2: Installation and Removal Procedures and Notes

- **Tools Needed**

- Tools necessary to make electrical connection.

- **Mounting Instructions**

Your PT-510/PT-510W series submersible pressure transducer is designed to be free-hanging.

- **Electrical Installation**

- Connect the wires of your PT-510 to your control system according to the pinout table above.

 **NOTE:** If your PT-510 has a vent tube, do not seal, cover, or close the vent tube with anything other than an APG-provided venting cap or desiccant drying cartridge (See Figure 3.1 and 3.2). Unapproved seals or covers will prevent proper sensor operation.

• **Removal Instructions**

Removing your PT-510/PT-510W from service must be done with care. It's easy to damage your sensor if you are not careful to follow these guidelines:

- Retrieve the sensor from the vessel. Follow any and all procedures for safely isolating any media contained inside the line or vessel.
- Carefully clean the sensor's fitting and diaphragm of any debris (see General Care) and inspect for damage.
- Store your sensor in a dry place, at a temperature between -40° F and 180° F.

Chapter 3: Maintenance

• **General Care**

Your PT-510/PT-510W series pressure transmitter is very low maintenance and will need little care as long as it is installed correctly. However, in general, you should:

- Avoid applications for which the transmitter was not designed, such as extreme temperatures, contact with incompatible corrosive chemicals, or other damaging environments.
- Avoid touching the diaphragm. Contact with the diaphragm, especially with a tool, could permanently shift the output and ruin accuracy.
- Clean the diaphragm or the diaphragm bore only with extreme care. If using a tool is required, make sure it does not touch the diaphragm.

i **IMPORTANT:** Any contact with the diaphragm can permanently damage the sensor. Use extreme caution.

- **Vent Tube Drying**

Condensation in the vent tube can damage the electronics in your sensor, resulting in unreliable readings. APG offers two methods of preventing vent tube condensation: a venting cap, and a desiccant drying cartridge.

The venting cap is a PVC tube with a hydrophobic patch that allows moisture to pass out of the tube without allowing water in (See Figure 3.1). The cap is sealed by an o-ring, and is easily installed in the field.

The desiccant drying cartridge with vent tube adapter absorbs any moisture in the vent tube to keep vapor from condensing (See Figure 3.2). The installation of the desiccant drying cartridge is quick and easy. Common installation methods are cable tie, Velcro, and cable clamps.



Figure 3.1



Figure 3.2

NOTE: Desiccant crystals change from blue to pink as they become saturated. Cartridge must be replaced when all crystals have saturated.

IMPORTANT: Do NOT use desiccant cartridge in the presence of vapors or liquids containing phosphate esters, synthetic lubricants, hydrocarbon solvents, methanol, acetone, lacquer solvents, or other organics.

- **Repair and Returns**

Should your PT-510 series pressure transmitter require service, please contact the factory via phone, email, or online chat. We will issue you a Return Material Authorization (RMA) number with instructions.

- Phone: 888-525-7300
- Email: sales@apgsensors.com
- Online chat at www.apgsensors.com

Please have your PT-510/PT-510W's part number and serial number available. See Warranty and Warranty Restrictions for more information.



Automation Products Group, Inc.

Tel: 1/888/525-7300 • Fax: 1/435/753-7490 • www.apgsensors.com • sales@apgsensors.com