

PT-300 Series

Amplified Output Pressure Transmitter

User Manual



CONTENTS

INTRODUCTION	III
WARRANTY AND WARRANTY RESTRICTIONS	IV
Repair and Returns	IV
CHAPTER 1: SPECIFICATIONS AND OPTIONS	1
Dimensions	1
Specifications	2
Model Number Configurator	3
Electrical Connector, Pinout Table, and Supply Power Table	4
Wiring Diagrams	5
CHAPTER 2: INSTALLATION AND REMOVAL PROCEDURES AND NOTES	6
Tools Needed	6
Mounting Instructions	6
Electrical Installation	6
Removal Instructions	6
CHAPTER 3: MAINTENANCE	7
General Care	7

INTRODUCTION

Thank you for purchasing a PT-300 Pressure Transmitter from APG. We appreciate your business! Please take a few minutes to familiarize yourself with your PT-300 and this manual.

The PT-300 series offers high accuracy and reliability over a wide range of pressures. The small size, integrated electronics, wide operating temperature ranges, and durability make PT-300 instruments perfect for static and dynamic pressure measurements with an amplified output signal.

Reading your label

Every APG instrument comes with a label that includes the instrument's model number, part number, serial number, and a wiring pinout table. Please ensure that the part number and pinout table on your label match your order.

WARRANTY AND WARRANTY RESTRICTIONS

This product is covered by APG's warranty to be free from defects in material and workmanship under normal use and service of the product for 24 months. For a full explanation of our Warranty, please visit <https://www.apgsensors.com/resources/warranty-certifications/warranty-returns/>. Contact Technical Support to receive a Return Material Authorization before shipping your product back.

Repair and Returns

Should your PT-300 series pressure transmitter require service, please contact the factory via phone, email, or online chat. We will issue you a Return Material Authorization (RMA) number with instructions.

- Phone: 888-525-7300
- Email: sales@apgsensors.com
- Online chat at www.apgsensors.com

Please have your PT-300's part number and serial number available.

CHAPTER 1: SPECIFICATIONS AND OPTIONS

Dimensions

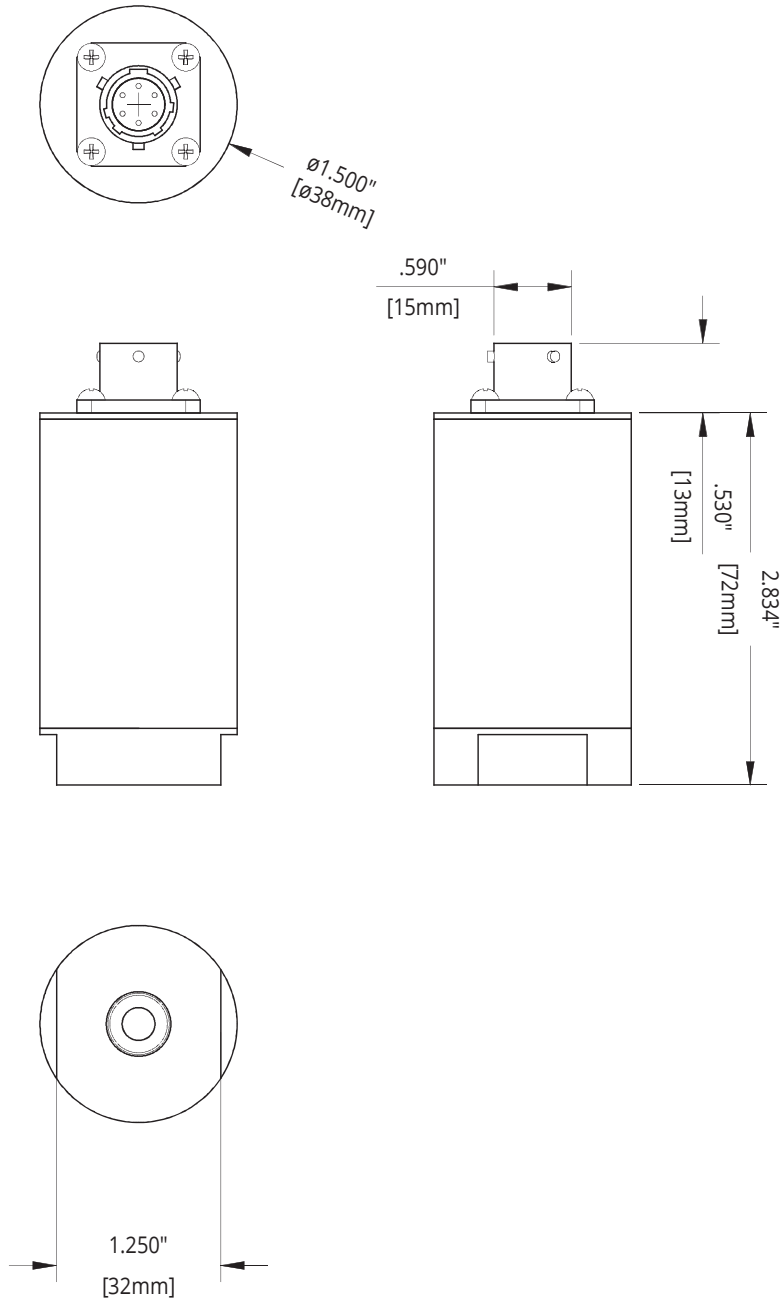

Specifications

Performance

Pressure Ranges	0 to 10K PSIS (Per Part Number)
Analog Output	4-20mA, 0-5VDC, 0-10VDC
Over Pressure	1.5X Full Scale or limit of fitting, whichever is less
Burst Pressure	3.0X Full Scale or limit of fitting, whichever is less

Accuracy

Linearity, Hysteresis & Repeatability	±1.0% of Full Scale (BFSL)
---------------------------------------	----------------------------

Environmental

Operating Temperature	-17 to 70°C / 0 to 158°F
Compensated Temperature	
≤ 10 psi:	0° to 60°C / 32° to 140°F
10 < x ≤ 1000 psi:	-10° to 70°C / 14° to 158°F
> 1000 psi:	-17° to 54°C / 0° to 130°F

Electrical

Supply Voltage (at sensor)	4-20 mA:	9-28 VDC
	0 to 5 VDC:	9-28 VDC
	0 to 10 VDC:	12.5-28 VDC
Output Signal @ 21°C / 70°F	4-20 mA:	3-30 mA max.
	0 to 5 VDC:	7mA max
	0 to 10 VDC:	14mA max

Materials of Construction

Wetted Materials	
≤ 1000 psi:	316L Stainless Steel
> 1000 psi:	17-4 Stainless Steel
Enclosure	316L Stainless Steel

Mechanical

Process Connection	1/4 - 18 NPTF
--------------------	---------------

Model Number Configurator

Model Number: PT-300 - - - - - - - - - - -

A B C D E F G H I J

A. Operation / Output

- L1▲** 4 - 20 mA output
- L3** 0 - 5 VDC output
- L10** 0 - 10 VDC output

B. Common Pressure Ranges - PSI*

- 5** **50** **300** **2000**
- 10** **60** **500** **3000**
- 15** **100** **750** **5000**
- 30** **200** **1000** **7500**

*Other ranges available. Please consult factory.

C. Units of Measure

- psi▲**

D. Pressure Type

- A** Absolute (≤ 200 psi)
- S▲** Sealed (≥ 4 psi)
- G** Gauge (≤ 500 psi)

E. Electrical Connection

(Mating connector sold separately)

- E4** M12 Connector
- E5▲** Pigtail with cable (specify cable length below)
- E17** 6 pin bayonet (PT02E-10-6P)
- E47** 6 pin bayonet (PT02E-10-6P) PIN A: +PWR/SIG
PIN D: -PWR/SIG

F. Electrical Cable Length

- Number represents cable length in ft to be included on E5 options.
(ex. E5-2 equals pigtail, 2 ft cable)

▲This option is standard

G. Process Connection

- P0** 1/4 - 18 NPTM
- P5▲** 1/4 - 18 NPTF

H. Accuracy

- N3▲** ±1.0%
- N4** ±1.0% with NIST certification

I. Materials

- M1** 316L SS (≤ 1000 psi)
- M2▲** 17-4 SS (> 1000 psi)

J. Temperature Compensation Range

- S11**

Operating Temperature	-17 to 70°C / 0 to 158°F
Compensated Temperature	
≤ 5 psi:	No temperature compensation
5 < x ≤ 10 psi	0° to 60°C / 32° to 140°F
10 < x ≤ 1000 psi:	-10° to 70°C / 14° to 158°F
> 1000 psi:	-17° to 54°C / 0° to 130°F

Electrical Connector, Pinout Table, and Supply Power Table

Below are pin out diagrams, a pin out table, and electrical cable specifications for the 4-20 mA, 0-5 VDC, and 0-10 VDC outputs, to assist you in wiring your transmitter.

PT-300 Pin Out Table

		4-20 mA	0-5 VDC	0-10 VDC
6 Pin Bayonet	A	+ Excitation	+ Excitation	+ Excitation
	B	- Excitation	+ Output	+ Output
	C	N/C	- Output	- Output
	D	N/C	- Excitation	- Excitation
	E	N/C	N/C	N/C
	F	N/C	N/C	N/C
4 Pin M12	1	+ Excitation	+ Excitation	+ Excitation
	2	- Excitation	+ Output	+ Output
	3	N/C	- Output	- Output
	4	N/C	- Excitation	- Excitation
Pigtail	Red	+ Excitation	+ Excitation	+ Excitation
	Grn	N/C	+ Output	+ Output
	Wht	N/C	- Output	- Output
	Blk	- Excitation	- Excitation	- Excitation

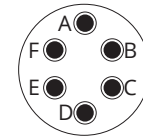

6 Pin Bayonet Connector

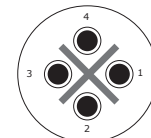

4 Pin M12 Micro Connector

4 Pin M12 Connector

N/C indicates no connection

For alternate pinouts, please consult factory

PT-300 Supply Power Table

	4-20 mA	0-5 VDC	0-10 VDC
Power Supply	9-28 VDC	9-28 VDC	12.5-28 VDC

Wiring Diagrams

4-20 mA

This device is a 2 wire, loop powered transmitter. A voltage of between 9 and 28 VDC must be maintained at this connection. Completion of the earth or system ground is recommended for proper circuit protection.

Power supply voltage must be sufficient to maintain a minimum of 9 VDC at the transducer/transmitter terminals after “dropping” voltage across R_L (the equivalent load resistance of the circuit) at full scale current (20 mA). Example: If $R_L = 250$ ohm then “drop” is $0.02 \text{ Amps} \times 250 \text{ ohm} = 5$ volts. Therefore power supply minimum is $5 \text{ V} + 9 \text{ V} = 14 \text{ V}$.

Typical 4-20 mA Circuit

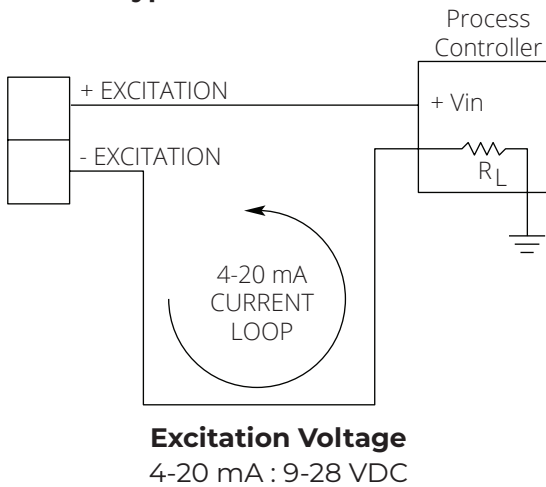

Typical 0-5 and 0-10 VDC Circuit

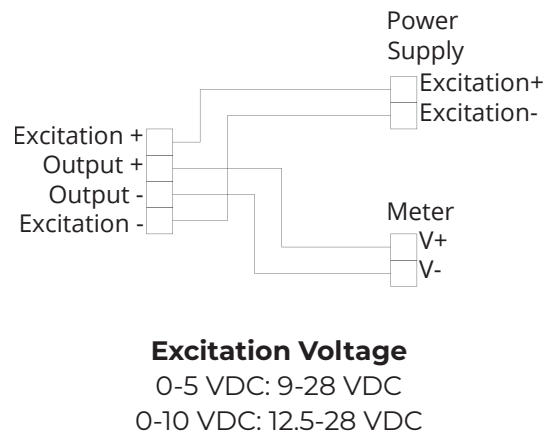

0-5 VDC and 0-10 VDC

0-5 and 0-10 VDC sensors are not as sensitive to circuit loading as 4-20 mA sensors are. As long as the power supply voltage (Excitation voltage) does not exceed 28 VDC, the sensor will operate properly.

CHAPTER 2: INSTALLATION AND REMOVAL PROCEDURES AND NOTES

Tools Needed

- Wrench sized appropriately for your PT-300's process connection.
- Thread tape or sealant compound for threaded connections.

Mounting Instructions

Mounting your pressure transmitter is easy if you follow a few simple steps:

- Never over-tighten the sensor. This can compress the diaphragm, changing how it reacts to pressure. In all cases, tighten the sensor as little as possible to create an adequate seal. On straight threads, tighten only until you feel the o-ring compress - making sure you don't damage or extrude the o-ring.
- Always use thread tape or sealant compound on tapered threads. Wrap thread tape in the opposite direction of the threads so it does not unravel as you screw the sensor into place. Unraveling can cause uneven distribution and seal failure. For straight threads use an o-ring.
- Always start screwing in your sensor by hand to avoid cross-threading. Thread failure can be a problem if you damage threads by over-tightening them or by crossing threads.

Electrical Installation

- Check the pinout table on your PT-300 against your order.
- Check that your electrical system wiring matches the pinout table on your PT-300.
- For instruments with connectors, make the connection. Otherwise, attach your wires to the provided terminal strip.

Removal Instructions

Removing your PT-300 from service must be done with care. It's easy to create an unsafe situation, or damage your sensor, if you are not careful to follow these guidelines:

- Make sure the pressure is completely removed from the line or vessel where your sensor is installed. Follow any and all procedures for safely isolating any media contained inside the line or vessel.
- Remove the sensor with an appropriately sized wrench (per your process connection).
- Clean the sensor's fitting and diaphragm of any debris (see General Care) and inspect for damage.
- Store your sensor in a dry place, at a temperature between -17° and 70° C (0° - 158° F).

DANGER: Removing your PT-300 Pressure Transmitter while there is still pressure in the line could result in injury or death.

CHAPTER 3: MAINTENANCE

General Care

Your PT-300 series pressure transmitter is very low maintenance and will need little care as long as it is installed correctly. However, in general, you should:

- Keep the transmitter and the area around it generally clean.
- Avoid applications for which the transmitter was not designed, such as extreme temperatures, contact with incompatible corrosive chemicals, or other damaging environments.
- Inspect the threads whenever you remove the transmitter from duty or change its location.
- Avoid touching the diaphragm. Contact with the diaphragm, especially with a tool, could permanently shift the output and ruin accuracy.
- Clean the diaphragm or the diaphragm bore with extreme care. If using a tool is required, make sure it does not touch the diaphragm.

IMPORTANT: Any contact with the diaphragm can permanently damage the sensor. Use extreme caution.



Automation Products Group, Inc.
Tel: 1 (888) 525-7300 or 1 (435) 753-7300

e-mail: sales@apgsensors.com
www.apgsensors.com

Automation Products Group, Inc.
1025 W. 1700 N.
Logan, UT 84321