

MNU-IS Series

Intrinsically Safe Ultrasonic Modbus Sensor

User Manual



CONTENTS

INTRODUCTION	III
Certifications	III
WARRANTY AND WARRANTY RESTRICTIONS	IV
CHAPTER 1: SPECIFICATIONS AND OPTIONS	1
Dimensions	1
Specifications	2
Model Number Configurator	3
Electrical Pinout Table, Supply Power Table, and System Wiring Diagrams	4
CHAPTER 2: INSTALLATION AND REMOVAL PROCEDURES AND NOTES	7
Tools Needed	7
Installation Notes	7
Physical Installation Notes	7
Electrical Installation	8
Mounting Instructions	8
Software Installation	8
Removal Instructions	8
CHAPTER 3: PROGRAMMING	9
Modbus Programming	9
Modbus Programming via Internet with RST-5003 or LOE	9
Modbus Programming with APG Modbus Software	10
MNU-IS Modbus Register Lists	10
MNU-IS Modbus Sensor Parameters	12
MNU-IS Web / Independent Modbus Alarm Parameters	18
MNU-IS Modbus Application Parameters	20
CHAPTER 4: QUICKMODE OPERATION AND NOTES	26
QuickMode Description	26
QuickMode Operation	26
QuickMode Operation Notes	26
QuickMode Communication Notes	27
QuickMode Settings	27
Using QuickMode	28
QuickMode Timing Example	29
CHAPTER 5: MAINTENANCE	30
General Care	30
Calibration	30
Troubleshooting	31
Loss of Echo	31
Repair and Returns	31
CHAPTER 6: HAZARDOUS INSTALLATION DRAWING	32
Hazardous Installation Drawing	32
APPENDIX A: MNU-IS DEFAULT HOLDING REGISTER VALUES	33
APPENDIX B: MNU-IS BARRIER NOTES	35
IS Barrier Notes	35

INTRODUCTION

Thank you for purchasing a Series MNU-IS Intrinsically Safe Modbus Ultrasonic Sensor from APG. We appreciate your business! Please take a few minutes to familiarize yourself with your MNU-IS and this manual.

MNU-IS ultrasonic sensors are rugged, low-power units, rated Intrinsically Safe for hazardous location installations. They feature APG's new QuickStart Mode for power-saving, on-demand measurements and optional Gas Discharge Tube surge protection. All MNU-IS sensors are fully programmable via RS-485 Modbus communications, and with APG Modbus software and an RS-485-to-USB converter.

Reading your label

Every APG instrument comes with a label that includes the instrument's model number, part number, serial number, and a wiring pinout table. Please ensure that the part number and pinout table on your label match your order.

Certifications



Class I Division 1, Groups C& D, T4
Class I, Zone 0, AEx ia IIB T4 Ga
Ex ia IIB T4 Ga



IECEX SIR 18.0048X
Ex ia IIB T4 Ga
0344 Ta: -30°C to 60°C



SIR 18ATEX2193X
II 1G Ex ia IIB T4 Ga
Ta: -30°C to 60°C

IMPORTANT: Your MNU-IS sensor MUST be installed according to drawing 9005002 (Hazardous Installation Drawing) located at the back of the manual to meet listed approvals. Faulty installation will invalidate all safety approvals and ratings.

WARRANTY AND WARRANTY RESTRICTIONS

This product is covered by APG's warranty to be free from defects in material and workmanship under normal use and service of the product for 24 months. For a full explanation of our Warranty, please visit <https://www.apgsensors.com/resources/warranty-certifications/warranty-returns/>. Contact Technical Support to receive a Return Material Authorization before shipping your product back.

CHAPTER 1: SPECIFICATIONS AND OPTIONS

Dimensions

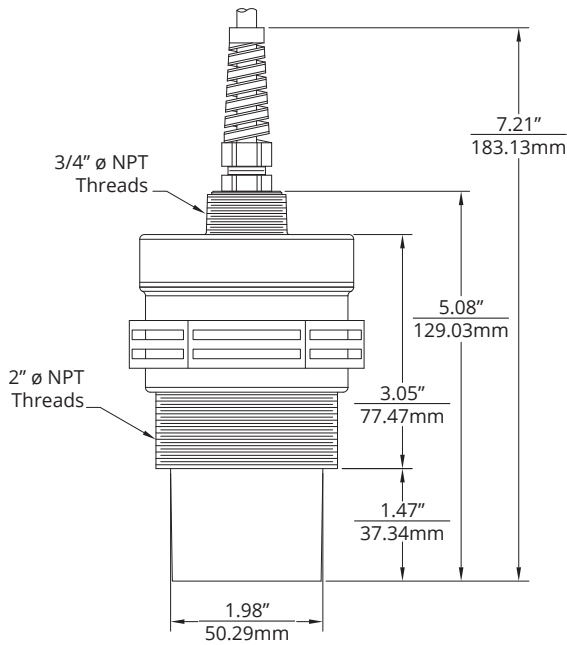

MNU-IS-6424 MNU-IS-6425
MNU-IS-8424 MNU-IS-8425

Housing Option 2

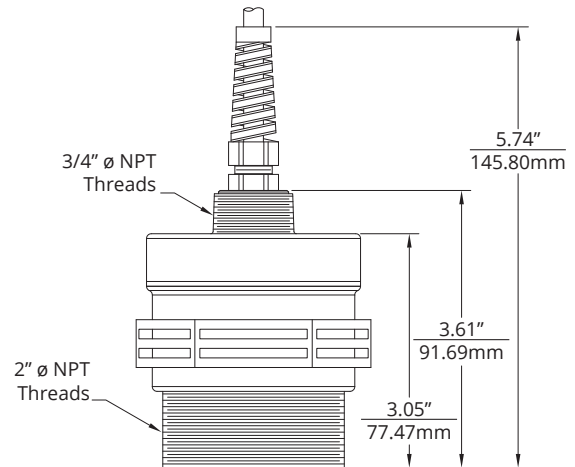

MNU-IS-6444 MNU-IS-6445
MNU-IS-8444 MNU-IS-8445

Housing Option 4

Specifications

Performance

Operating Range / Transducer Frequency	
Option 6: 69 KHz (-30 to 60°C)	1.0 - 25.0 ft. / 12 in. - 300 in. / 305mm - 7620mm
Option 8: 81 KHz	0.42 - 12.0 ft. / 5 in. - 144 in. / 125mm - 3658mm
Digital Output	Modbus, via RS-485
Beam Pattern	9° off axis
Sample Rate	1 - 20 Hz
Response Time	Programmable

Accuracy

Accuracy	Greater of $\pm 0.25\%$ of detected range or $\pm 3\text{mm}$
Resolution	0.1 inch (2.54 mm)

Environmental

Operating & Storage Temperature	Ambient -22 to 140°F (-30 to 60°C) unless otherwise specified
Internal Temperature Compensation	Yes
Humidity	100% non-condensing
IP rating	IP68, submerged 3 meters for 48 hours M12 connector rated IP67

Electrical

Supply Voltage (at sensor)	8-24 VDC
Operating Current Draw (dependent on setup)	
	@ 8 VDC: Min = 32 mA, Max = 63 mA rms
	@ 24 VDC: Min = 18 mA, Max = 26 mA rms
Waiting Status Current Draw	
	@ 8 VDC: 17 mA rms
	@ 24 VDC: 13 mA rms
Connection	2 Shielded Twisted Pair and drain wire
Cable Approved For IS Use	Consolidated Electronic Wire & Cable, P/N: 5594-CL

Materials of Construction

Transducer Face	
Housing Option 2, 4	PVDF
Housing	PBT/Polycarbonate blend

Mounting

Housing Option 2, 4	2" NPT (Housing body), 3/4" NPT (Lid)
---------------------	---------------------------------------

IS Entity Parameters

See Hazard Drawing 9005002 at back of manual for IS Entity Parameter listing.

Model Number Configurator

Model Number: MNU - IS - _____ - _____
 A B C D E F G

A. Range, Frequency

- 6** 1 - 25 ft. (305 - 7620 mm); 69 kHz Transducer
- 8▲** 5 - 144 in. (127 - 3658 mm); 81 kHz Transducer

B. Lid Interface Threads

- 4▲** 3/4 in. MNPT

C. Housing

- 2▲** 2 in. MNPT, Valox PBT
- 4** 2 in. MNPT, Valox PBT, Recessed Transducer

D. Output

- 4▲** RS-485 Modbus RTU, Intrinsically Safe
- 5** RS-485 Modbus RTU, Intrinsically Safe w/ Gas Discharge Tube Surge Protection

E. Cable

- C▲** Shielded Cable with Flying Leadst†
- N** No Cable

F. Electrical Cable Length

- _____ Specify Length (6 ft. standard length + 5 ft. increments)
- 0** No Cable

G. Seal

- A▲** Cable Gland with Spiral Strain Relief
- B** Cable Gland
- C** Cable Gland (Atex)
- M** M12 Micro Connector†

Note: ▲Indicates this option is standard.

† For mating connection & cable with M12 Micro Connector, use Cable and Cable Length in sections E & F.

Note: Approved mating connector and cable required with M12 Micro Connector for IS use. Contact factory for information.

Electrical Pinout Table, Supply Power Table, and System Wiring Diagrams

MNU Series Pinout Table

Pigtail (2 Twisted Pairs)		Modbus
	Red	8 - 24 VDC
	Black	DC Ground
	Green	B (TX-)
	White	A (TX+)
	Shield Drain	Earth Gnd at IS Barrier or Supply
Micro Connector	1	+24 VDC
	2	A (TX+)
	3	DC Ground
	4	B (TX-)
	5*	Earth Gnd at Supply

Note: *Micro connector on MNU-IS with lightning protection has 5 pins. Micro connector on MNU-IS without lightning protection has 4 pins. All cables have 4 wires and shield drain.

MNU Series Supply Power Table

	Modbus
Power Supply	8-24 VDC

IMPORTANT: Some manufacturer's Modbus equipment uses reversed TX+/TX- pins. When making connections to any Modbus equipment, reversing connections may be necessary if sensor does not communicate with controller.

IMPORTANT: Approved mating connector and cable required with M12 Micro Connector for IS use. Use of non-approved mating connector and/or cable will invalidate IS rating.

Modbus System Wiring

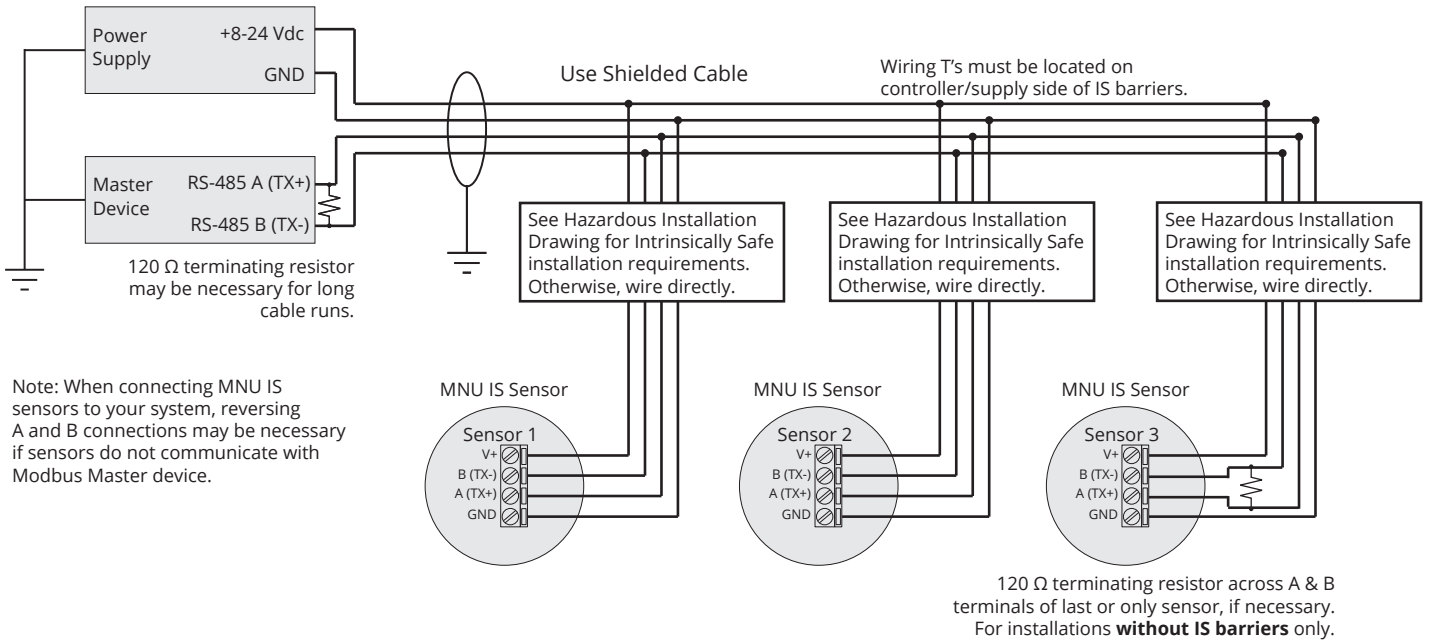

Note: When connecting MNU IS sensors to your system, reversing A and B connections may be necessary if sensors do not communicate with Modbus Master device.

Modbus System Wiring with RST-6001

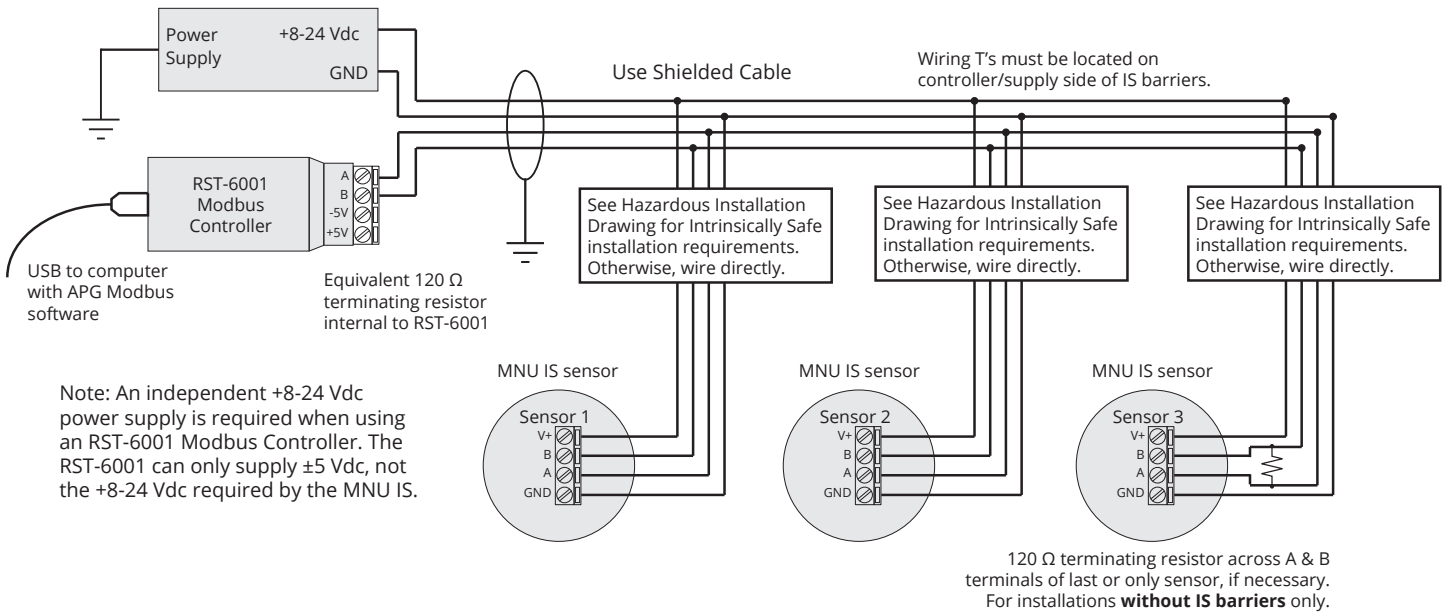

Note: An independent +8-24 Vdc power supply is required when using an RST-6001 Modbus Controller. The RST-6001 can only supply ±5 Vdc, not the +8-24 Vdc required by the MNU IS.

IMPORTANT: Your MNU-IS sensor **MUST** be installed according to drawing 9005002 (Hazardous Installation Drawing) located at the back of the manual to meet listed approvals. Faulty installation will invalidate all safety approvals and ratings.

Modbus System Wiring with RST-5003 and Independent Power Supply

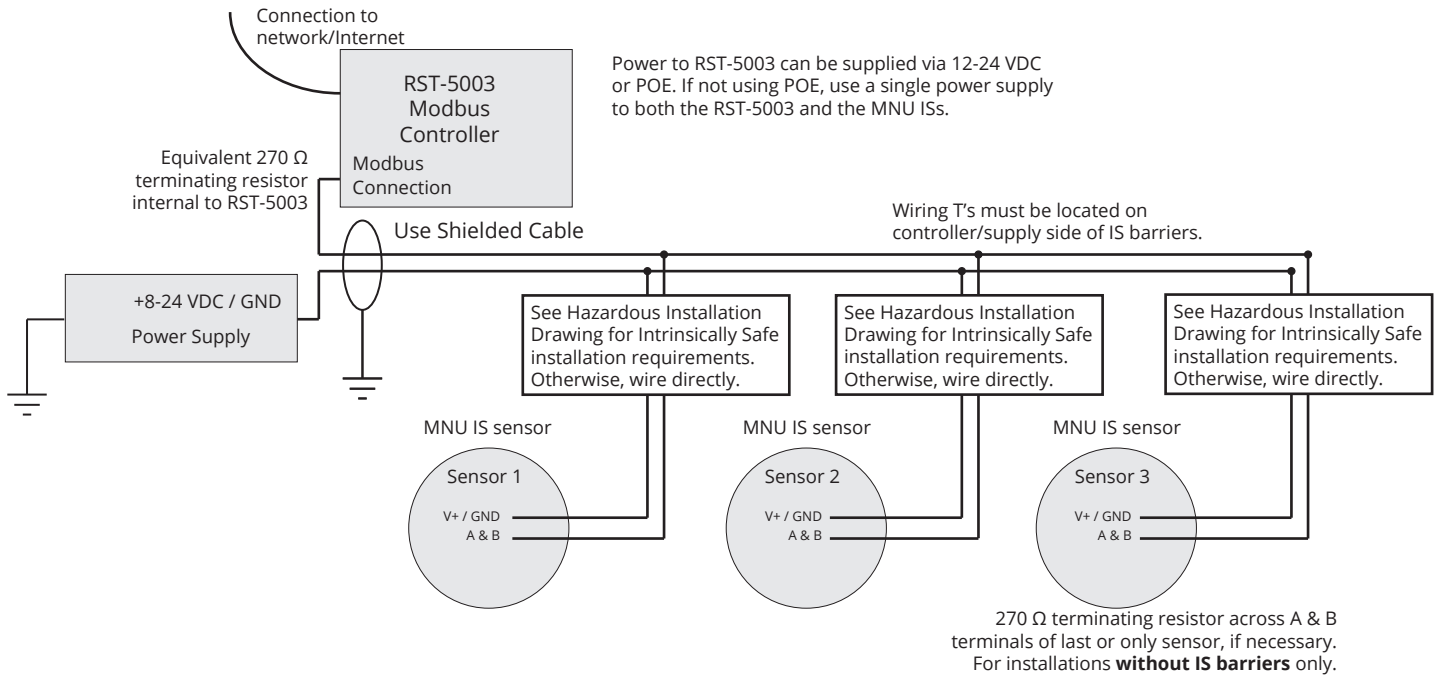

Modbus System Wiring with RST-5003 and POE or VDC Daisy Chain

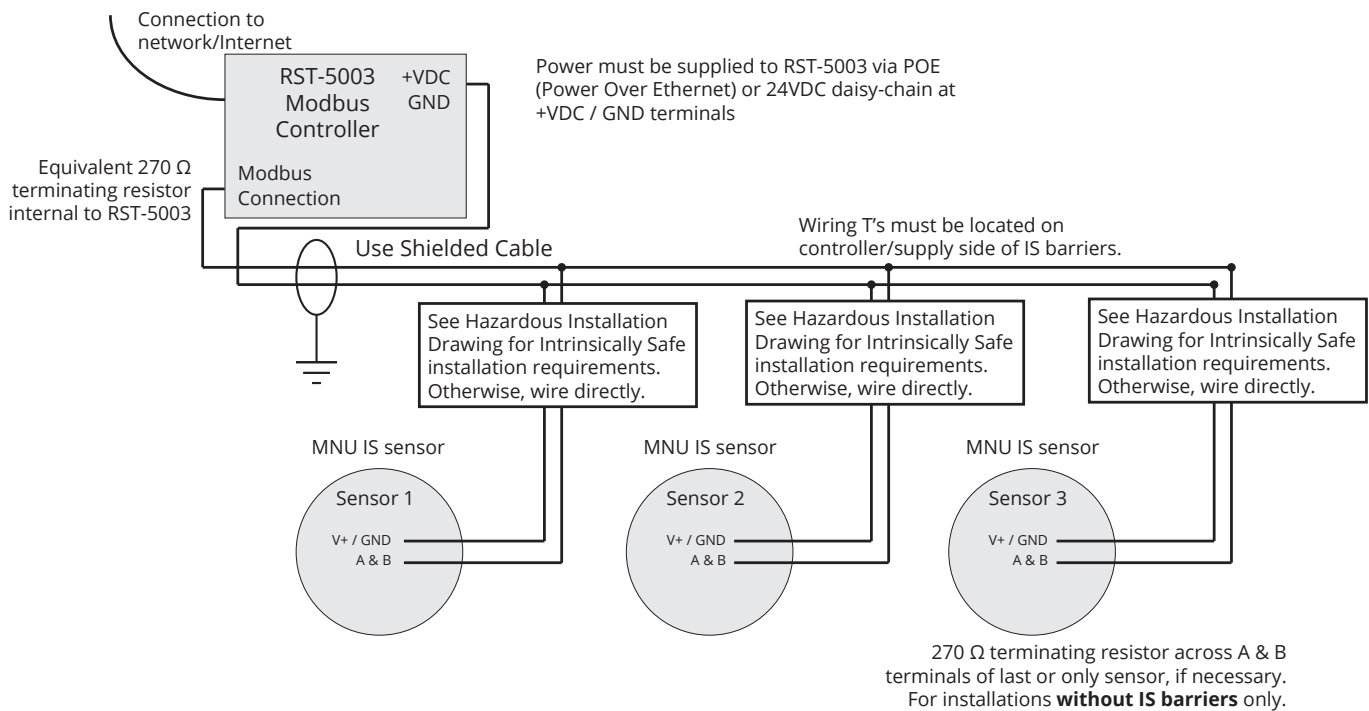

IMPORTANT: Your MNU-IS sensor MUST be installed according to drawing 9005002 (Hazardous Installation Drawing) located at the back of the manual to meet listed approvals. Faulty installation will invalidate all safety approvals and ratings.

CHAPTER 2: INSTALLATION AND REMOVAL PROCEDURES AND NOTES

Tools Needed

Typical tools for making electrical connections and mounting the sensor are required. If you are using a stand pipe to mount your MNU-IS, you may also need tools to install the stand pipe.

Installation Notes

- Mount your MNU-IS sensor so that it has a clear, perpendicular sound path to the surface being monitored. Your sensor should be mounted away from tank or vessel walls and inlets. (See Figure 2.1)
- The sound path should be free from obstructions and as open as possible for the 9° off axis beam pattern.
- If you are using a stand pipe, please see our guide to stand pipes on our website: <http://www.apgsensors.com/about-us/blog/how-to-install-a-stand-pipe>.

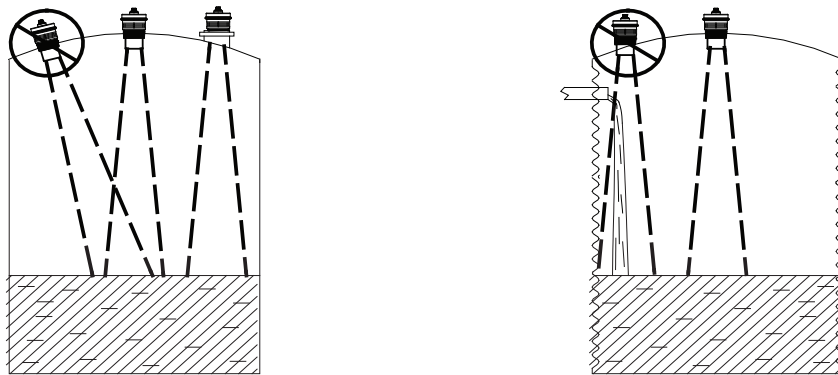

Figure 2.1

Physical Installation Notes

The MNU-IS should be installed in an area—indoors or outdoors—which meets the following conditions:

- Ambient temperature between -22°F to 140°F (-30°C to 60°C), unless otherwise specified.
- No chemicals corrosive to PVDF or PBT.
- Ample space for maintenance and inspection.
- The sensor is located away from strong electromagnetic fields, such as those produced by motors, transformers, solenoid valves, etc.
- The sensor is not exposed to excessive vibration.
- The sensor is shielded from direct sunlight or from temperatures different than the temperatures between the sensor and the target. This is required for temperature compensation to work correctly.
- The equipment shall be installed in a location where the external conditions are not conducive to the build-up of electrostatic charge on the sensor. The equipment shall only be cleaned with a damp cloth.

Electrical Installation

Attach the wires of your MNU-IS to your control system according to the pinout table on page 4.

IMPORTANT: Some manufacturer's Modbus equipment uses reversed TX+/TX- pins. When making connections to any Modbus equipment, reversing connections may be necessary if sensor does not communicate with controller.

Mounting Instructions

Mounting your MNU-IS is easy if you follow a few simple steps:

- Never over-tighten the sensor.
- Always screw in your sensor by hand to avoid cross-threading. Thread failure can be a problem if you damage threads by over-tightening them or by crossing threads.

IMPORTANT: Do not over tighten! The sensor should be threaded in only hand tight.

NOTE: Do not mount the sensor where the beam will intersect objects such as fill streams, pipes, ladder rungs, wall seams, or corrugated tank walls.

Software Installation

- Download the APG MNU IS Modbus software zipfile from <https://www.apgsensors.com/resources/product-resources/software-downloads/>.
- Open the zip file.
- Choose "Install" from the options at the top of the zip file window.
- The installation process will prompt you as needed to complete the installation.
- The software will create APG_Modbus.exe which will run from a folder in your start menu titled "APG/APG_Modbus".

Removal Instructions

- Ensure that power to the sensor is off.
- Disconnect cable to sensor.
- Remove the sensor and store it in a dry place, at a temperature between -22°F to 140°F (-30°C to 60°C), unless otherwise specified.
- If the sensor was installed in a hazardous location, ensure that the cable will not energize while the sensor is disconnected.

DANGER: Do not disconnect equipment installed in hazardous locations unless power has been switched off or area is known to be non-hazardous.

CHAPTER 3: PROGRAMMING

Modbus Programming

MNU-IS series sensors use standard Modbus RTU protocol (RS-485). The sensors can only operate as slave devices. Sensor default transmission settings are **9600 Baud, 8 Bits, 1 Stop Bit, No Parity**, and require a minimum delay of 200-300 ms between transactions to return the contents of all registers. Commands returning fewer registers will require shorter delays. See MNU-IS Modbus Register Lists on pages 10 - 11.

NOTE: For more information about Modbus RTU, please visit www.modbus.org.

Modbus Programming via Internet with RST-5003 or LOE

MNU-IS Modbus series sensors can be programmed, controlled, and monitored via the Internet (or local Ethernet) using an RST-5003 web-enabled Modbus master controller or LOE web-enabled Modbus master sensor. One RST-5003 or LOE can control and monitor up to 10 APG Modbus-equipped sensors. Please refer to the RST-5003 User Manual or LOE User Manual for further instructions and help setting up and operating an RST-5003 or LOE and using either one to program and control MNU-IS sensors.

NOTE: For the RST-5003 User Manual or LOE User Manual, please visit our website at: <https://www.apgsensors.com/resources/product-resources/user-manuals/>

Modbus Programming with APG Modbus Software

APG Modbus software can be used in tandem with an APG RST-6001 Modbus Controller to program and control up to 20 MNU-IS sensors. Through the APG Modbus software, you can monitor the raw readings from the sensor, or configure the sensor. See MNU-IS Modbus Register Lists below.

NOTE: For APG Modbus programming instructions, or to download APG Modbus software, please visit <https://www.apgsensors.com/resources/product-resources/software-downloads/>

MNU-IS Modbus Register Lists

Input Registers (0x04)

Register	Returned Data
30299	Model Type
30300	Raw Distance/Level Reading (in mm, unsigned)
30301	N/A
30302	Temperature Reading (in 0C, signed)
30303-30304	Calculated (raw)
30305-30306	N/A
30307 (upper byte)	Version
30307 (lower byte)	Signal Strength
30308	N/A
30309 (upper byte)	Trip 1 Alarm
30309 (lower byte)	Trip 1 Status
30310 (upper byte)	Trip 2 Alarm
30310 (lower byte)	Trip 2 Status
30314-30318	10 Byte Sensor Serial Number
30500-30598	Quickmode Samples

NOTE: The Calculated Readings will be returned without a decimal place. In order to obtain the true result, the Decimal Place setting must be taken into account.

Holding Registers (0x03) - MNU-IS

Register	Function	Value Range
40400	Device Address	1 to 247
40401	Units	1 = Feet, 2 = Inches, 3 = Meters
40402	Application Type	0 - 11
40403	Volume Units	1 - 7
40404	Decimal (Calculated)	0 - 3
40405	Max Distance	0 - 15,250 mm
40406	Full Distance	0 - 15,250 mm
40407	Empty Distance	0 - 15,250 mm
40408	Sensitivity	0 - 100
40409	Pulses	0 - 20
40410	Blanking	0 - 15,250 mm
40411	Gain Control	0 - 5
40412	Averaging	1 - 100
40413	Filter Window	0 - 15,250 mm
40414	Out of Range	1 - 255
40415	Sample Rate	50 - 1000 milliseconds
40416	Multiplier	1 - 1999 (1,000 = 1.000)
40417	Offset	-15,250 - 15,250 mm
40418	N/A	
40419	N/A	
40420	Temperature Compensation	0 = No, 1 = Yes
40421	QuickMode Enable	0 - 98
40422	QuickMode Delay	0 - 65535 ms
40423	Pulse Power	10 - 100%
40424-40425	N/A	
40426	4 mA Set Point	*N/A
40427	20 mA Set Point	*N/A
40428	4 mA Calibration	*N/A
40429	20 mA Calibration	*N/A
40430	Trip 1 Value	0 - 15,250 (mm)
40431	Trip 1 Window	0 - 15,250 (mm)
40432	Trip 1 Type	0 - 29
40433	Trip 2 Value	0 - 15,250 (mm)
40434	Trip 2 Window	0 - 15,250 (mm)
40435	Trip 2 Type	0 - 29
40436-40437	Parameter 1	0 - 1,000,000 (mm)
40438-40439	Parameter 2	0 - 1,000,000 (mm)
40440-40441	Parameter 3	0 - 1,000,000 (mm)
40442-40443	Parameter 4	0 - 1,000,000 (mm)
40444-40445	Parameter 5	0 - 1,000,000 (mm)
40446-40459	Reserved For Factory Use Only	
40187	QuickMode Resample	Non-Zero Number
40201	Reset to Factory Defaults	1

*These registers are not used by the MNU-IS, even though they are labeled in the APG Modbus software.

MNU-IS Modbus Sensor Parameters

40401 - Units

Determines the units of measure for the calculated reading when Application Type is set to 0, 1, or 7.

1 = Feet 2 = Inches 3 = Meters

40402 - Application Type

Determines the type of calculated reading performed by the sensor.

0 = Distance
1 = Depth of Level
2 = Volume of Standing Cylindrical Tank with or without Hemispherical Bottom
3 = Volume of Standing Cylindrical Tank with or without Conical Bottom
4 = Volume of Standing Rectangular Tank with or without Chute Bottom
5 = Volume of Horizontal Cylindrical Tank with or without Spherical Ends
6 = Volume of Spherical Tank
7 = Pounds (Linear Scaling)
8 = N/A
9 = Volume of Vertical Oval Tank
10 = Volume of Horizontal Oval Tank
11 = Curve Fit (Strapping Chart)

See MNU-IS Application Parameters on pages 19 - 24 for parameter configurations for each application.

40403 - Volume Units

Determines the units of measure for the calculated reading when Application Type is set to 2 - 6 or 9 -11.

1 = Feet³ 5 = Liters
2 = Million Feet³ 6 = Inches³
3 = Gallons 7 = Barrels
4 = Meters³

40404 - Decimal Place

Determines the number of decimal places included in the Calculated Reading. The Calculated Reading will always be returned as a whole number.

For example, a Calculated Reading of 1126.658 (gallons, ft³, etc.) will be returned as follows:

Decimal Place = 0	Volume = 1127 (rounded to nearest whole number)
Decimal Place = 1	Volume = 11267 (divide by 10 to get true result)
Decimal Place = 2	Volume = 112666 (divide by 100 to get true result)
Decimal Place = 3	Volume = 1126658 (divide by 1000 to get true result)

40405 - Maximum Distance

Sets the distance (beginning from the Zero Point) to the point where the sensor will stop looking for target signals. Targets detected beyond the Maximum Distance value will be ignored by the sensor. Maximum Distance + Offset (Holding Register 40417) cannot exceed the sensor's maximum operating range (see Operating Range / Transducer Frequency in Specifications, page 2).

40406 - Full Distance

Sets the distance (beginning from the Zero Point) to the point where the monitored vessel is considered full.

40407 - Empty Distance

Sets the distance (beginning from the Zero Point) to the point where the monitored vessel is considered empty.

40408 - Sensitivity

Sets the level of gain that is applied to the echo (0-100%). When operating in AutoSense, Hard-Target, or Soft-Target (see Gain Control, Holding Register 40411), Sensitivity sets an upper limit for the amplification that can be applied to the echo. If operating in Manual, this parameter sets the gain.

When using Manual Gain Control, set Sensitivity to the minimum value that will allow the target to be reliably tracked through the full range of expected environmental conditions (i.e., apply only as much amplification as necessary). This reduces power usage and extends transducer life.

40409 - Pulses

Sets the number of ultrasonic pulses per transmission burst (0-20). The more pulses that are sent in a burst, the stronger the returning echo. For Gain Control (Holding Register 40411) settings Auto Sense, Hard Target, and Soft Target, this setting limits the maximum number of pulses used by the sensor.

When Gain Control is set to Manual, increase the strength of the transmission by increasing Pulses or Pulse Power (Holding Register 40423) for detecting soft targets in damping environments. In acoustically active environments or small enclosed areas, decrease Pulses or Pulse Power to reduce multiple echoes.

NOTE: When Gain Control is set to Manual, Hard-Target, or Soft-Target, set Sensitivity (40408) and Pulses (40409) to maximum values, as these are the upper limits used by the sensor.

40410 - Blanking

Sets the blanking distance, which is the zone from the Zero Point of the sensor to the point from which the first echo will be accepted. While blanking distance can be used to ignore unwanted targets—such as welds, seams, pipe fittings, or gaskets—between the sensor and the closest acceptable target level, such objects generally create additional reflections and echoes, which are hard to filter out. More often, blanking distance is used for a sensor installed in a stand pipe.

NOTE: Increases in Pulses (40409) may require increased Blanking (40410).

40411 - Gain Control

Selects the control mode governing the sensor's gain settings (Sensitivity and Pulses, Holding Registers 40408 and 40409). In general, using the lowest combined settings of Sensitivity and Pulses that allow for a high-quality return signal will consume less power and extend the life of the transducer.

In Manual, the sensor ramps up the effective sensitivity until it matches the setting in Sensitivity. No signal optimization is calculated/performed.

In Autosense, the sensor ramps the effective sensitivity and pulses until an optimal return signal (Signal Strength, Input Register 30307 lower byte) is reached. Should the return signal change, the sensor will adjust the gain settings.

In Hard-Target, the sensor ramps the effective sensitivity up slower than in Manual, since hard (or close) targets return better signals quicker. Ramping the sensitivity slower allows any initial ringing to clear before the sensor begins "listening" for return signals.

In Soft-Target, the sensor ramps the effective sensitivity up quicker than in Manual, since soft (or further away) targets take longer to return high-quality signals.

Autosense Soft-Target combines the quick-ramping and maximum settings of Soft-Target with the continuous, automatic adjustment of Autosense.

Autosense Hard-Target combines the slow-ramping and maximum settings of Hard-Target with the continuous, automatic adjustment of Autosense.

- 0 = Manual
- 1 = AutoSense
- 2 = Hard-Target
- 3 = Soft-Target
- 4 = AutoSense Soft-Target
- 5 = AutoSense Hard-Target

NOTE: When Gain Control is set to Manual, Hard-Target, or Soft-Target, Sensitivity (40408) and Pulses (40409) settings are the maximum possible values used by the sensor.

NOTE: For most applications, AutoSense, AutoSense Soft-Target, or AutoSense Hard-Target will provide the best results. Manual, Hard-Target, and Soft-Target are best used for troubleshooting.

40412 - Averaging

Sets the number of qualified received signals (0-100) to average for the displayed reading. Qualified received signals are placed in a first-in, first-out buffer, the contents of which are averaged for the displayed output. The larger the number of qualified received signals being averaged, the smoother the output reading will be, and the slower the reading will be to react to quickly changing targets.

40413 - Filter Window

Determines the physical range (0 - 15,250 mm) of qualified received signals, based on the current reading. Signals beyond the +/- Filter Window range of the current reading will not qualify unless the average moves. Signals outside the extents of the Filter Window are written to the Out of Range samples buffer (Holding Register 40414).

40414 - Out of Range

Sets the number of consecutive samples outside the Filter Window (Holding Register 40413) necessary to automatically adjust the current reading and move the Filter Window.

40415 - Sample Rate

Sets the time delay between samples taken by the sensor (50 - 1000 ms). While shorter time delays allow for quicker sensor response times to changing levels, longer sample rate delays reduce the likelihood of echo-based false positives. Also, longer sample rates result in longer sensor life.

40416 - Multiplier

Calibrates the sensor for changes in the speed of sound due to variations in atmospheres. The Multiplier is shown by the values 1 - 1999, but these values are understood to represent 0.001 - 1.999. The default of 1,000 (i.e., 1.000) is used for most applications. See the Calibration section of Chapter 4.

40417 - Offset

Sets the Zero Point of the sensor, the point from which the calculated distance is measured. When the Offset is set to 0, the Zero Point of the sensor is at the face of the transducer (See Figure 3.1). A positive setting will move the Zero Point forward, in front of the sensor face (See Figure 3.2). Setting the Offset to a negative number will move the Zero Point backward, behind the sensor face (See Figure 3.3).

In all cases, Blanking (Holding Register 40410) is measured from the end of Offset, and the effective measurement zone of the sensor begins at the forward end of Blanking. If Offset is more negative than Blanking is positive, the net difference will be a loss in sensor maximum range (See Figure 3.3).

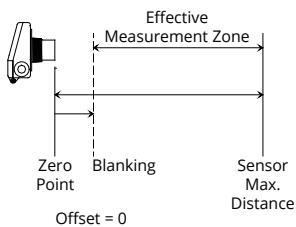

Figure 3.1

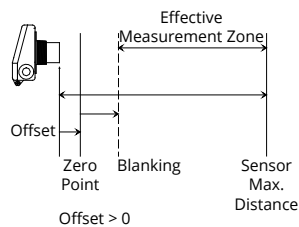

Figure 3.2

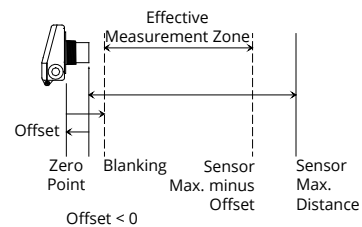

Figure 3.3

40420 - Temperature Compensation

Activates or deactivates the MNU-IS's internal temperature compensation circuit (1 = On, 0 = Off). The speed of sound changes with changes in temperature, therefore changes in temperature affect distance measurements. These effects can be minimized by activating temperature compensation.

40421 - QuickMode

Sets the number of samples to average for quick distance reading on power up or QuickMode Resample (0 = Off, 1 - 99 = number of samples to average). Unaveraged samples can be read from Register 30500 - 30598. See QuickMode Operation and Notes on page 26-29.

40422 - QuickMode Delay

Specifies the length of delay, in number of milliseconds, before the sensor begins taking QuickMode samples. This delay includes the time needed to power up the sensor. Power up takes 250 ms, so a QuickMode Delay setting of 250 will result in samples starting immediately after the power up time. To delay the sensor's samples 500 ms (half a second) beyond power up, QuickMode Delay should be set to 750.

See QuickMode Operation and Notes on page 26-29.

40423 - Pulse Power

Set the percentage of power (10-100) that will be used for each pulse transmission. The higher the percentage of pulse power the stronger the returning echo will be.

When Gain Control (Holding Register 40411) is set to Manual, increase the strength of the transmission by increasing Pulses (Holding Register 40409) or Pulse Power for detecting soft targets in damping environments. In acoustically active environments or small enclosed areas, decrease Pulses or Pulse Power to reduce multiple echoes.

NOTE: Pulse Power is independent of Gain Control (Holding Register 40411), and is not effected by any of its settings.

40446-459 - Internal Factory Settings

The registers are reserved for factory use. Overwriting these registers may prevent your sensor from operating properly.

IMPORTANT: Overwriting Holding Registers 40446 - 40459 may cause your sensor to not work.

40187 - QuickMode Resample

Initiates a QuickMode sample from a sensor in waiting status whenever a non-zero value is written to this register. See QuickMode Operation and Notes on page 26-29.

40201 - Reset to Factory Defaults

Resets all Holding Registers to factory default values when 1 is written to this register.

NOTE: Factory Reset does not overwrite Device Address (Holding Register 40400).

MNU-IS Web / Independent Modbus Alarm Parameters

MNU-IS sensors interfaced with an LOE web-enabled master sensor or an RST-5003 web-enabled master controller can be configured to generate website alarms via levelandflow.com. Refer to the LOE or RST-5003 user manuals (available on <https://www.apgsensors.com/resources/product-resources/user-manuals/>) for more information.

MNU-IS sensors do not have physical, or electronic, trip outputs. Via LOE or RST-5003 web-enabled devices, Holding Registers 40430 - 40435 can be configured to create outputs in Input Registers 30309 and 30310 that will trigger alarms through web interfaces. These registers can also be configured/monitored via RS-485 Modbus programming, but APG Modbus software cannot be used to generate such alerts or alarms.

40430 - Trip 1 Value

40433 - Trip 2 Value

Sets the distance (0 - 15,250 mm) to the trip position closest to the sensor face.

40431 - Trip 1 Window

40434 - Trip 2 Window

Sets the distance (0 - 15,250 mm) from the first trip position to the trip position farthest from the sensor face.

40432 - Trip 1 Type

40435 - Trip 2 Type

Sets the Trip Type for web outputs or independently-configured Modbus outputs. Trip Types are configured with two independent digits: the first for Alarm Type (1, or 2), and the second for Trip Condition (0-5, 7, or 9).

Alarm Type _____

1_ - Active Alarm

Designates the active trip point as an alarm condition. To initiate an alarm whenever the Trip Type **_3** is active (on), Trip Type would be set to **13**.

Alarm Type _____

2_ - Inactive Alarm

Designates an inactive trip point as an alarm condition. To initiate an alarm whenever the Trip Type **_3** is inactive (off), Trip Type would be set to **23**.

Trip Condition

_0 - Near

Near activates the trip status whenever the target surface is closer than the Trip Value setting.

Trip Condition

_1 - Exclusive

Exclusive activates the trip status whenever the target surface is closer than the Trip Value setting OR beyond the Trip Value + Trip Window setting.

Trip Condition

_2 - Hysteresis Near

Hysteresis Near activates the trip status whenever the target surface moves closer than the Trip Value setting. The trip status remains activated until the target surface moves beyond the Trip Value + Trip Window setting. The trip status remains off until the target surface moves closer than the Trip Value setting again.

Trip Condition

_3 - Far

Far activates the trip status whenever the target surface is beyond the Trip Value setting.

Trip Condition

_4 - Inclusive

Inclusive activates the trip status whenever the target surface is beyond the Trip Value setting AND closer the Trip Value + Trip Window setting.

Trip Condition

_5 - Hysteresis Far

Hysteresis Far activates the trip status whenever the target surface moves beyond the Trip Value + Trip Window setting. The trip status remains activated until the target surface moves closer than the Trip Value setting. The trip status remains off until the target surface moves beyond the Trip Value + Trip Window setting again.

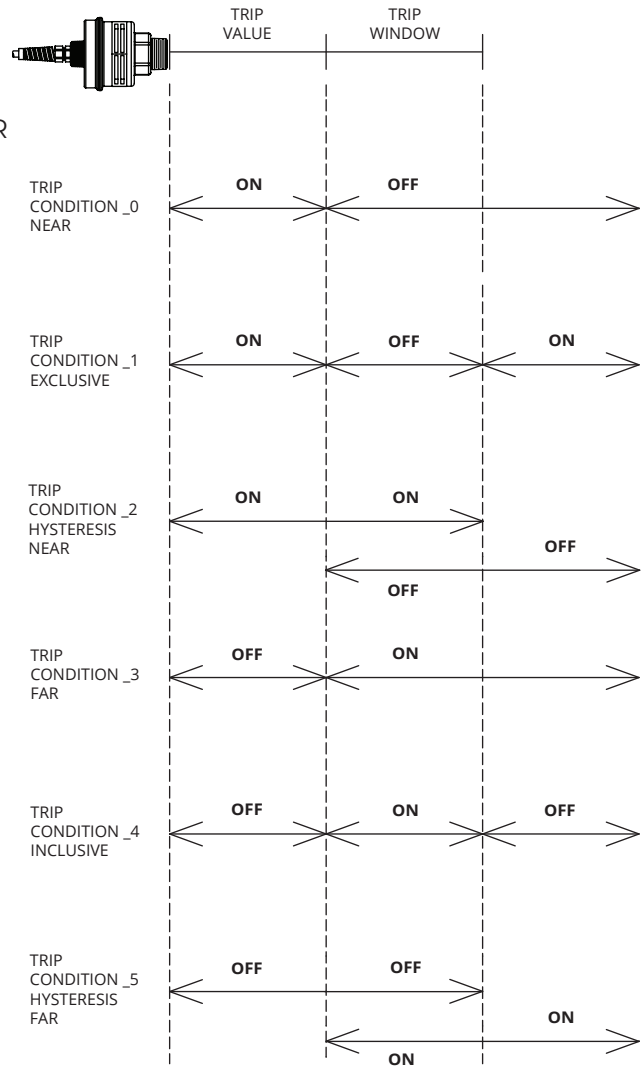

Trip Condition

_6 - N/A

Trip Condition

_7 - Loss of Echo

Loss of Echo activates the trip status whenever no target is detected within the Maximum Distance (Holding Register 40405).

Trip Condition

_8 - N/A

Trip Condition

_9 - Rate of Change

Rate of Change activates the trip status whenever a user-defined maximum rate of level change (change in distance or level divided by elapsed time) is exceeded. Trip Value (Holding Register 40430 or 40433) defines the distance and Trip Window (Holding Register 40431 or 40434) defines the time.

MNU-IS Modbus Application Parameters

Each MNU-IS application (Holding Register 40402) uses a specific configuration of certain Holding Registers. Below are the configurations of registers used by each application. Images defining tank dimensions assume sensor placement at the top of or above tank.

Application 0 - Distance

Register	Function	Value Range
40400	Device Address	1 to 247
40401	Units	1 = Feet, 2 = Inches, 3 = Meters
40402	Application Type	0
40403	Volume Units	—
40404	Decimal (Calculated)	0 - 3
40405	Max Distance	0 - 15,250 mm

Application 1 - Depth of Level

Register	Function	Value Range
40400	Device Address	1 to 247
40401	Units	1 = Feet, 2 = Inches, 3 = Meters
40402	Application Type	1
40403	Volume Units	—
40404	Decimal (Calculated)	0 - 3
40405	Max Distance	Less than Empty Distance
40406	Full Distance	Typically = Blanking Distance
40407	Empty Distance	0 - 15,250 mm

Application 2 - Volume of Standing Cylindrical Tank ± Hemispherical Bottom

Register	Function	Value Range
40400	Device Address	1 to 247
40401	Units	—
40402	Application Type	2
40403	Volume Units	1 - 7
40404	Decimal (Calculated)	0 - 3
40405	Max Distance	Less than Empty Dist.
40406	Full Distance	Typ. = Blanking Dist.
40407	Empty Distance	0 - 15,250 mm
40436-40437	Tank Diameter	0 - 1,000,000 (mm)
40438-40439	Radius of Bottom Hemisphere	0 - 1,000,000 (mm)

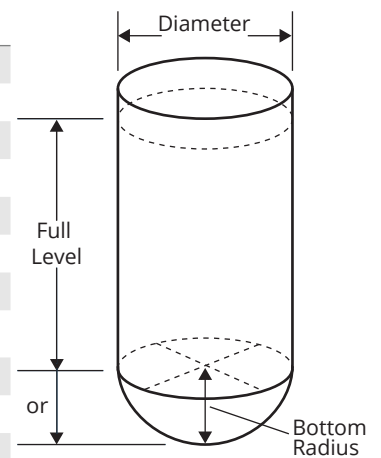

Application 3 - Volume of Standing Cylindrical Tank ± Conical Bottom

Register	Function	Value Range
40400	Device Address	1 to 247
40401	Units	—
40402	Application Type	3
40403	Volume Units	1 - 7
40404	Decimal (Calculated)	0 - 3
40405	Max Distance	Less than Empty Dist.
40406	Full Distance	Typ. = Blanking Dist.
40407	Empty Distance	0 - 15,250 mm
40436-40437	Tank Diameter	0 - 1,000,000 (mm)
40438-40439	Cone Diameter (at bottom of cone)	0 - 1,000,000 (mm)
40440-40441	Length (height) of Cone	0 - 1,000,000 (mm)

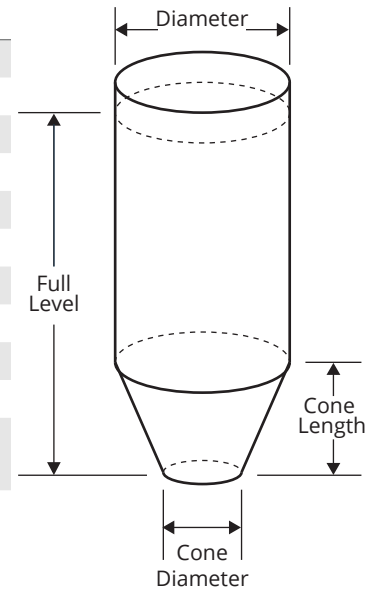

Application 4 - Volume of Standing Rectangular Tank ± Chute Bottom

Register	Function	Value Range
40400	Device Address	1 to 247
40401	Units	—
40402	Application Type	4
40403	Volume Units	1 - 7
40404	Decimal (Calculated)	0 - 3
40405	Max Distance	Less than Empty Dist.
40406	Full Distance	Typ. = Blanking Dist.
40407	Empty Distance	0 - 15,250 mm
40436-40437	Tank X Dimension	0 - 1,000,000 (mm)
40438-40439	Tank Y Dimension	0 - 1,000,000 (mm)
40440-40441	Chute X Dimension	0 - 1,000,000 (mm)
40442-40443	Chute Y Dimension	0 - 1,000,000 (mm)
40444-40445	Length (height) of Chute	0 - 1,000,000 (mm)

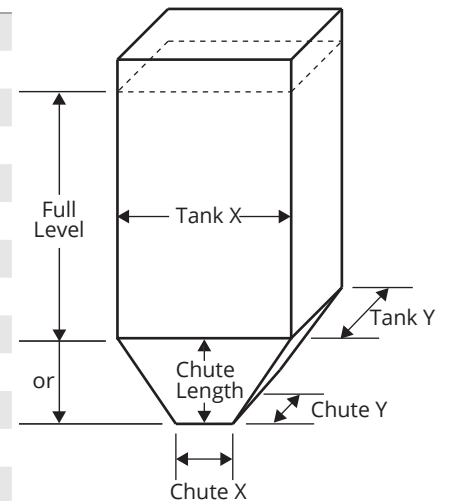

Application 5 - Volume of Horizontal Cylindrical Tank ± Hemispherical Ends

Register	Function	Value Range
40400	Device Address	1 to 247
40401	Units	—
40402	Application Type	5
40403	Volume Units	1 - 7
40404	Decimal (Calculated)	0 - 3
40405	Max Distance	Less than Empty Dist.
40406	Full Distance	Typ. = Blanking Dist.
40407	Empty Distance	0 - 15,250 mm
40436-40437	Tank Length	0 - 1,000,000 (mm)
40438-40439	Tank Diameter	0 - 1,000,000 (mm)
40440-40441	Radius of End Hemispheres	0 - 1,000,000 (mm)

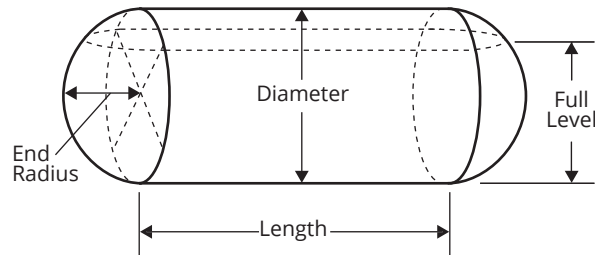

Application 6 - Volume of Spherical Tank

Register	Function	Value Range
40400	Device Address	1 to 247
40401	Units	—
40402	Application Type	6
40403	Volume Units	1 - 7
40404	Decimal (Calculated)	0 - 3
40405	Max Distance	Less than Empty Dist.
40406	Full Distance	Typ. = Blanking Dist.
40407	Empty Distance	0 - 15,250 mm
40436-40437	Tank Diameter	0 - 1,000,000 (mm)

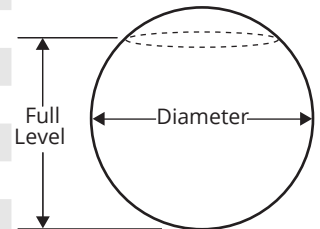

Application 7 - Pounds (Linear Scaling)

Register	Function	Value Range
40400	Device Address	1 to 247
40401	Units	1 = Feet, 2 = Inches, 3 = Meters
40402	Application Type	7
40403	Volume Units	—
40404	Decimal (Calculated)	0 - 3
40405	Max Distance	Less than Empty Dist.
40406	Full Distance	Typ. = Blanking Dist.
40407	Empty Distance	0 - 15,250 mm
40436-40437	Multiplier (linear scalar)	0 - 1,000,000 (1000 = 1.000)

Application 9 - Volume of Vertical Oval Tank

Register	Function	Value Range
40400	Device Address	1 to 247
40401	Units	—
40402	Application Type	9
40403	Volume Units	1 - 7
40404	Decimal (Calculated)	0 - 3
40405	Max Distance	Less than Empty Dist.
40406	Full Distance	Typ. = Blanking Dist.
40407	Empty Distance	0 - 15,250 mm
40436-40437	Tank Length	0 - 1,000,000 (mm)
40438-40439	Tank Depth	0 - 1,000,000 (mm)
40440-40441	Tank Width	0 - 1,000,000 (mm)

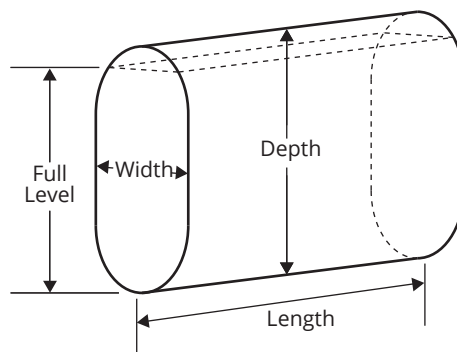

Application 10 - Volume of Horizontal Oval Tank

Register	Function	Value Range
40400	Device Address	1 to 247
40401	Units	—
40402	Application Type	10
40403	Volume Units	1 - 7
40404	Decimal (Calculated)	0 - 3
40405	Max Distance	Less than Empty Dist.
40406	Full Distance	Typ. = Blanking Dist.
40407	Empty Distance	0 - 15,250 mm
40436-40437	Tank Length	0 - 1,000,000 (mm)
40438-40439	Tank Depth	0 - 1,000,000 (mm)
40440-40441	Tank Width	0 - 1,000,000 (mm)

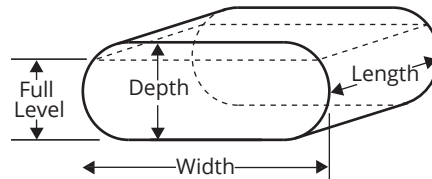

Application 11 - Strapping Chart (Curve Fit Polynomial Values)

Register	Function	Value Range
40400	Device Address	1 to 247
40401	Units	1 = Feet, 2 = Inches, 3 = Meters
40402	Application Type	11
40403	Volume Units	1 - 7
40404	Decimal (Calculated)	0 - 3
40405	Max Distance	Less than Empty Dist.
40406	Full Distance	Typ. = Blanking Dist.
40407	Empty Distance	0 - 15,250 mm
40436-40437	X ³ Coefficient	0 - 1,000,000
40438-40439	X ² Coefficient	0 - 1,000,000
40440-40441	X ¹ Coefficient	0 - 1,000,000
40442-40443	X ⁰ Coefficient	0 - 1,000,000

NOTE: The Coefficient values must be calculated in the Units selected. The Coefficients will not adjust if Units is changed after they are set.

CHAPTER 4: QUICKMODE OPERATION AND NOTES

QuickMode Description

When a sensor with QuickMode enabled is turned on, it powers up (250 ms), waits a user-specified set amount of time (as few as 0 milliseconds), takes a prescribed number of measurements, averages them, then sets the output reading and sends an unprompted report to the Modbus network. The sensor then goes into a low-power waiting state, from which it can be prompted to take another QuickMode reading, or powered off.

QuickMode Operation

1. Sensor is off, or in waiting status.
2. Sensor is powered on, or receives QuickMode Resample instruction (Holding Register 40187). Either powerup process takes 250 ms to complete. Time specified in QuickMode Delay begins counting at Power ON, not completion of Power UP.
3. Sensor waits for any remaining time specified in QuickMode Delay (Holding Register 40422) after completion of Power Up.
4. Sensor takes number of samples specified in QuickMode (Holding Register 40421). Sample readings are written to QuickMode Samples (Input Registers 30500 - 30598).
5. Samples are averaged.
6. The result is written to Raw Distance/Level Reading (Input Register 30300), and reported in an unrequested communication packet on the Modbus network.
7. Sensor enters, or returns to, low-power waiting status.

QuickMode Operation Notes

While the sensor is in low-power waiting status:

- It can receive Modbus instructions, and return Input and Holding Register values.
- It does not update Input Register 30300 (Raw Distance/Level Reading) value.
- It will power up for a new QuickMode measurement when any non-zero number is written to QuickMode Resample Instruction (Holding Register 40187), or if the number of QuickMode samples (40421) is changed.

NOTE: A Read request of Input Register 30300 while a QuickMode sensor is in waiting status will return the value of the most recent QuickMode reading.

QuickMode Communication Notes

1. The communication packet includes: sensor Model Type (30299), Raw Distance/Level Reading (30300), pulse width (Signal Strength 30307, lower byte), Temperature Reading in C° (30302), and Calculated (raw) (30303-30304).
2. The communication packet is unrequested (i.e., it is not part of standard communication). The master device must be set to listen for the response.
3. Any sniffing device on the Modbus network can read/receive the packet.

QuickMode Settings

The following settings govern the operation of the MNU-IS in QuickMode:

- QuickMode (Holding Register 40421) sets the number of samples to be averaged.
- QuickMode Delay (Holding Register 40422) determines the length of delay after sensor power up before the first sample is taken.
- When a non-zero number is written to QuickMode Resample Instruction (Holding Register 40187), a sensor in waiting status initiates QuickMode operation.

For multiple sensors on the same network, or redundant sensors in close proximity with one another, use QuickMode Delay (Holding Register 40422) to sequence each sensor's sampling to prevent unwanted acoustical crosstalk.

NOTE: Cycling the power of your MNU-IS will not affect its QuickMode settings. Only changing Holding Register 40421 to or from 0 will initiate or exit QuickMode.

Using QuickMode

To successfully use QuickMode:

- Ensure that your Modbus Master is set up to listen for and receive the response packet after initiating QuickMode.
- Ensure that your MNU-IS settings are optimized for the installation (Sensitivity, Pulses, Pulse Power, etc).
- Ensure that your MNU-IS is calibrated for the distance.
- Set the desired time delay in QuickMode Delay (40422).
- When all other settings are properly configured, set the number of QuickMode samples to be averaged (40421).

The following general sensor settings must be configured for optimal sensor operation prior to initiating QuickMode for accurate QuickMode readings:

- Max Distance (Holding Register 40405)
- Pulses (Holding Register 40409), Sensitivity (Holding Register 40408), and Pulse Power (Holding Register 40423)

To initiate QuickMode:

- Write the number of desired QuickMode samples to Holding Register 40421.

To exit QuickMode (return to normal sensor operation):

- Write 0 to Holding Register 40421.

NOTE: Your MNU-IS must be calibrated (see Calibration in Chapter 5) before initiating QuickMode.

QuickMode Timing Example

The following QuickMode example shows how to calculate the approximate amount of time from powering on an MNU-IS sensor until the first reading is reading is written in Input Register 30300.

Register settings for this QuickMode example:

- **Max Distance** (40405): 4572 mm
- **Pulses** (40409): 5 (pulses per sample)
- **QuickMode Delay** (40422): 0 (milliseconds)
- **QuickMode samples** (40421): 5

Total Time = Base Time + Distance Adjustment + Effective QuickMode Delay

Base Time = (**QuickMode Samples** x 100) + 150

Base Time = (5 x 100) + 150 = 500 + 150 = 650 ms

Distance Adjustment = (**QuickMode Samples** x 10) x ((**Max Distance** / 1829) - 1)

Distance Adjustment = (5 x 10) x ((4572 / 1829) - 1) = 50 x (2.5 - 1) = 50 x 1.5 = 75 ms

Effective QuickMode Delay = **QuickMode Delay** - 250

Since **QuickMode Delay** counting begins at Power On, the 250 ms of Start up time must be subtracted from any value over 250. **QuickMode Delay** values between 0 and 250 have no effect on the timing.

Total Time = 650 ms + 75 ms + 0 ms = 725 ms

If the target is closer than the maximum distance, the Travel Time will lessen accordingly, thus bringing down the Total Time.

For MNU-IS sensors used in a redundant configuration, figure the Total Time for the first sensor, add at least 250 ms (a quarter second) for time between the two sensors, and use the sum as the **QuickMode Delay** for the second sensor.

Using the example set up above, a redundant sensor should have a **QuickMode Delay** of at least 975 (725 + 250).

NOTE: Sound waves are affected by the physical environment, including temperature and elevation. These calculations are based on observations at ~4550' and 21°C.

NOTE: A Modbus Master with only one MNU-IS operating in QuickMode can be set to be ready to receive the response packet immediately after sending the QuickMode Sample/Resample instruction in order to avoid making the timing calculations.

CHAPTER 5: MAINTENANCE

General Care

Your MNU-IS ultrasonic sensor is very low maintenance and will need little care as long as it was installed correctly. However, in general, you should:

- Avoid applications for which the sensor was not designed, such as extreme temperatures, contact with incompatible corrosive chemicals and fumes, or other damaging environments.
- Protect against water or ice buildups on the face of the sensor.
- Inspect the threads whenever you remove the sensor from duty or change its location.

Calibration

This procedure uses targets at known distances to calibrate the sensor's accuracy. A wall or other large, flat object is recommended for the long range target.

- Point the sensor at a target at a known distance near the maximum range of the sensor (See Figure 4.1).
- Adjust the Multiplier value until the distance reading on the sensor matches the actual measured distance to the target (Holding Register 40416).
- Point the sensor at a target near the minimum measurement range, approximately 1 foot, plus any Blanking distance (See Figure 4.2).
- Adjust the Offset value until the distance reading on the sensor matches the actual measured distance to the target (Holding Register 40417).
- Repeat previous two steps until no further adjustment is required.



Figure 4.1

Figure 4.2

NOTE: If the MNU-IS is to be used in an environment with changing temperatures, all calibration steps must be done with Temperature Compensation (Holding Register 40420) set to 1 (On).

Troubleshooting

Should you have problems with your MNU-IS, here are some troubleshooting steps.

- If your MNU-IS sensor is not communicating, try reversing the connection of the A and B Modbus wires from the sensor into your control system/Modbus Network.
- Check the received signal strength (Input Register 307). If the signal strength is low, alternately increase Pulse Power, Pulses, and Sensitivity (Holding Registers 40423, 40409, and 40408) until the signal strength improves.
- Ensure Temperature Compensation (Holding Register 40420) is On (set to 1).
- Set the Gain Control to AutoSense (Holding Register 40411).
- Ensure that Blanking (Holding Register 40410) is accurately set to account for any unwanted targets between the sensor and the closest acceptable target.
- Ensure that your control system/Modbus Network has not written to Holding Registers 40446 - 40459. Writing to these registers may disable your sensor.

Loss of Echo

When the sensor can no longer detect returning sound waves—called Loss of Echo—the output will match empty tank conditions.

- For Application Type 0 (Holding Register 40402), Distance Mode, the output will match the Max Distance Value (Holding Register 40405).
- For all Level/Volume Application Types 1 - 11, the output will go to 0.

Repair and Returns

Should your MNU-IS ultrasonic sensor require service, please contact the factory via phone, email, or online chat. We will issue you a Return Material Authorization (RMA) number with instructions.

- Phone: 888-525-7300
- Email: sales@apgsensors.com

Please have your MNU-IS sensor's part number and serial number available. See Warranty and Warranty Restrictions for more information.

CHAPTER 6: HAZARDOUS INSTALLATION DRAWING

Hazardous Installation Drawing

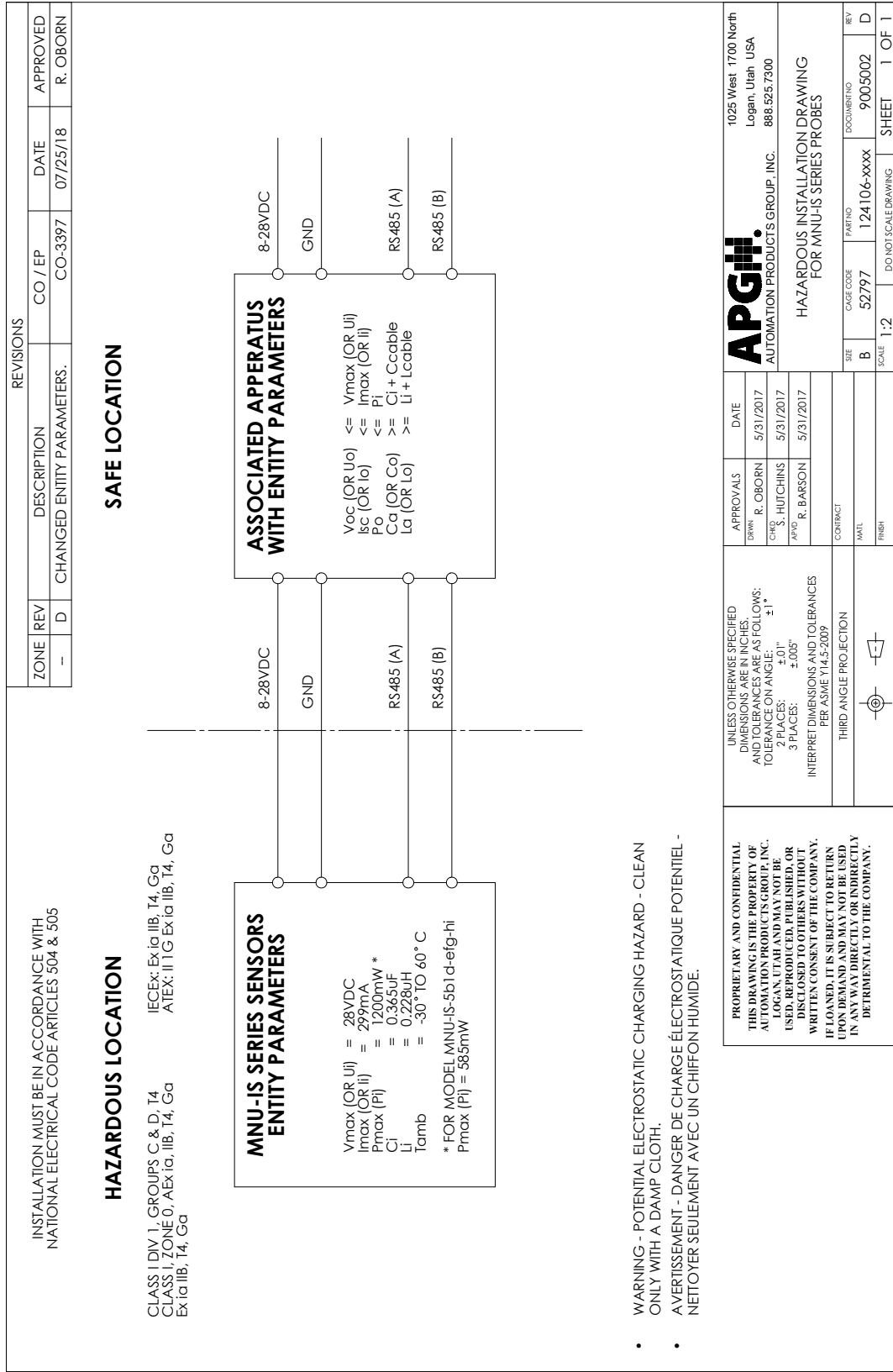

IMPORTANT: To meet Intrinsically Safe installation requirements, barrier(s) used must meet "Associated Apparatus with Entity Parameters" shown in drawing 9005002.

APPENDIX A: MNU-IS DEFAULT HOLDING REGISTER VALUES

Holding Registers (0x03) - MNU-IS (69 kHz)

Register	Function	Default Settings
40400	Device Address	1
40401	Units	3
40402	Application Type	0
40403	Volume Units	1
40404	Decimal (Calculated)	3
40405	Max Distance	8,000 (mm)
40406	Full Distance	305 (mm)
40407	Empty Distance	8,000 (mm)
40408	Sensitivity	100
40409	Pulses	20
40410	Blanking	300 (mm)
40411	Gain Control	1
40412	Averaging	10
40413	Filter Window	50 (mm)
40414	Out of Range	10
40415	Sample Rate	250 milliseconds
40416	Multiplier	1.000 (1,000)
40417	Offset	-6 mm
40418	N/A	
40419	N/A	
40420	Temperature Compensation	1 (Yes)
40421	QuickMode Enable	0
40422	QuickMode Delay	0
40423	Pulse Power	90
40424-40425	N/A	
40426	4 mA Set Point	*N/A
40427	20 mA Set Point	*N/A
40428	4 mA Calibration	*N/A
40429	20 mA Calibration	*N/A
40430	Trip 1 Value	0
40431	Trip 1 Window	0
40432	Trip 1 Type	0
40433	Trip 2 Value	0
40434	Trip 2 Window	0
40435	Trip 2 Type	0
40436-40437	Parameter 1	0
40438-40439	Parameter 2	0
40440-40441	Parameter 3	0
40442-40443	Parameter 4	0
40444-40445	Parameter 5	0
40187	QuickMode Resample	0
40201	Reset to Factory Defaults	0

*These registers are not used by the MNU-IS, even though they are labeled in the APG Modbus software.

Holding Registers (0x03) - MNU-IS (81 kHz)

Register	Function	Default Settings
40400	Device Address	1
40401	Units	3
40402	Application Type	0
40403	Volume Units	1
40404	Decimal (Calculated)	3
40405	Max Distance	4,400 (mm)
40406	Full Distance	130 (mm)
40407	Empty Distance	4,400 (mm)
40408	Sensitivity	100
40409	Pulses	7
40410	Blanking	127 (mm)
40411	Gain Control	1
40412	Averaging	10
40413	Filter Window	50 (mm)
40414	Out of Range	10
40415	Sample Rate	250 milliseconds
40416	Multiplier	1.000 (1,000)
40417	Offset	-6 mm
40418	N/A	
40419	N/A	
40420	Temperature Compensation	1 (Yes)
40421	QuickMode Enable	0
40422	QuickMode Delay	0
40423	Pulse Power	75
40424-40425	N/A	
40426	4 mA Set Point	*N/A
40427	20 mA Set Point	*N/A
40428	4 mA Calibration	*N/A
40429	20 mA Calibration	*N/A
40430	Trip 1 Value	0
40431	Trip 1 Window	0
40432	Trip 1 Type	0
40433	Trip 2 Value	0
40434	Trip 2 Window	0
40435	Trip 2 Type	0
40436-40437	Parameter 1	0
40438-40439	Parameter 2	0
40440-40441	Parameter 3	0
40442-40443	Parameter 4	0
40444-40445	Parameter 5	0
40187	QuickMode Resample	0
40201	Reset to Factory Defaults	0

*These registers are not used by the MNU-IS, even though they are labeled in the APG Modbus software.

APPENDIX B: MNU-IS BARRIER NOTES

IS Barrier Notes

Devices rated Intrinsically Safe for use in hazardous locations require the use of barriers to limit the total amount of electrical and thermal energy present in the device and circuit within the the hazardous area. The allowable limits—called entity parameters—for the MNU-IS, as determined by CSA, are listed on drawing 9005002.

Barriers for Modbus devices are more difficult to deal with than 4-20 mA devices, as the limits are stated in total but must account for both the supply voltage and the communication signal. This can be accomplished with one barrier or two.

Below is an example of using two barriers, and their resultant entity parameters, which together meet CSA’s requirements for use with the MNU-IS.

IMPORTANT: Case ground of IS barrier(s) must be connected to Equipment Ground on supply side.

24 VDC Barrier (APG P/N 200187)

Line	Barrier Specifications				Entity Parameter Requirements				
	Voltage	Rmin	Rmax	I _{max}	V _{max}	I _{max}	P _{max}	L _{max}	C _{max}
V+	24 VDC	241 Ω	252 Ω	100 mA	28 VDC	119 mA	833 mW	0.228 μH	—

RS-485 Barrier (APG P/N 200186)

Line	Barrier Specifications				Entity Parameter Requirements				
	Voltage	Rmin	Rmax	I _{max}	V _{max}	I _{max}	P _{max}	L _{max}	C _{max}
TX+	9 VDC	1043 Ω	1156 Ω	7.7 mA	12 VDC	12 mA	40 mW	850 μH	9 μF
TX-	9 VDC	1043 Ω	1156 Ω	7.7 mA	12 VDC	12 mA	40 mW	850 μH	9 μF
Total	18 VDC	—	—	—	24 VDC	24 mA	80 mW	145 μH	0.93 μF

IMPORTANT: To meet Intrinsically Safe installation requirements, barrier(s) used must meet “Associated Apparatus with Entity Parameters” shown in drawing 9005002.



Automation Products Group, Inc.
Tel: 1 (888) 525-7300 or 1 (435) 753-7300

e-mail: sales@apgsensors.com
www.apgsensors.com

Automation Products Group, Inc.
1025 W. 1700 N.
Logan, UT 84321