

Thank You

Thanks for purchasing a PT-503 Series Submersible Pressure Transmitter from us! We appreciate your business and your trust. Please take a moment to familiarize yourself with the product and this manual before installation. If you have any questions, don't hesitate to call us at 888-525-7300.

You can find a full list of our product manuals at:

www.apgsensors.com/resources/product-resources/user-manuals

Table of Contents

- | | | |
|------------------------------------|--------------------------|-------------------------|
| 1. Description | 4. General Care | 7. Vent Tube Drying |
| 2. How To Read Your Label | 5. Dimensions | 8. Wiring Information |
| 3. Warranty and Return Information | 6. Mounting Instructions | 9. Removal Instructions |

1 Description

The PT-503 Series Submersible Pressure Sensor brings precision level measurement to harsh chemical environments. Engineered with advanced materials, the PT-503 can be used in many places that stainless steel and PVC can't go. With user-friendly analog output options and the ability to submerge it up to 69 feet (21 meters) underwater (30 psig), the PT-503 simplifies the process of obtaining dependable level measurements in challenging chemical environments.

2 How To Read Your Etched Label

Each sensor comes with a label etched in the body with a full model number, a part number, and a serial number. The model number for the PT-503 will look something like this:

SAMPLE: PT-503-7.5-PSI-G-L1-30-N12

The model number correlates with all the configurable options and tells you exactly what you have. Compare the model number to the options on the datasheet to identify your exact configuration. You can also call us with the model, part, or the serial number and we can help you.

The label also includes the pinout, as does this installation guide.

3 Warranty and Return Information

This product is covered by APG's warranty to be free from defects in material and workmanship under normal use and service of the product for 24 months. For a full explanation of our Warranty, please visit <https://www.apgsensors.com/resources/warranty-certifications/warranty-returns/>. Contact Technical Support to receive a Return Material Authorization (RMA) before shipping your product back.

If your pressure transmitter needs to be returned for evaluation, contact us via email, phone, or on-line chat on our website. We will issue you an RMA number with instructions.

- Phone: 888-525-7300
- Email: sales@apgsensors.com
- Online chat at www.apgsensors.com

Please have your PT-503's part number and serial number available.

4 General Care

Your pressure transmitter is very low maintenance and will need little care, as long as it was installed correctly. However, in general, you should:

- Avoid applications for which the sensor was not designed, such as extreme temperatures, contact with incompatible corrosive chemicals, or other damaging environments.
- Avoid touching the diaphragm. Contact with the diaphragm, especially with a tool, could permanently shift the output and ruin accuracy.
- Cleaning the diaphragm or the diaphragm bore should be done with extreme care. If using a tool is required, make sure it does not touch the diaphragm.

IMPORTANT: Any contact with the diaphragm can permanently damage the sensor. Use extreme caution.

PT-503 SERIES SUBMERSIBLE PRESSURE TRANSMITTER

4-20 mA, 0.5 – 4.5 VDC

Installation Guide



Automation Products Group, Inc.
1025 W 1700 N Logan, UT 84321
www.apgsensors.com | phone: 888-525-7300 | email: sales@apgsensors.com

Part # 201052
Doc #9005951 Rev A

5 Dimensions

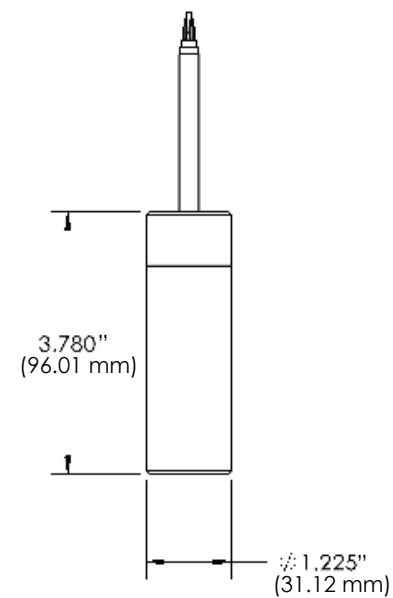

PT-503

6 Mounting Instructions

The PT-503 should be installed in an area—indoors or outdoors—which meets the following conditions:

- Ambient temperature between 0°F and 158°F (-18°C to 70°C)
- Relative humidity up to 100%
- IEC-664-1 Conductive Pollution Degree 1 or 2
- IEC 61010-1 Measurement Category II
- Ample space for maintenance and inspection
- Class II power supply

Your PT-503 Series Submersible Pressure Transmitter is designed to be free-hanging. It can safely lay on the bottom of the tank or pool. If your tank contains sediment, it is recommended to suspend the PT-503 just above the sediment layer.

Common installation methods include mounting a cable clamp or grip at the top of a tank to prevent the cord from falling into the tank.

7 Vent Tube Drying

Condensation in the vent tube can damage the electronics in your sensor, resulting in unreliable readings. APG offers two methods of preventing vent tube condensation: a venting cap, and a desiccant drying cartridge. By default, the PT-503 comes with a venting cap pre-installed.

The venting cap is a PVC tube with a hydrophobic patch that allows moisture to pass out of the tube without allowing water in. The cap is sealed by an o-ring, and is easily installed in the field.

The desiccant drying cartridge with vent tube adapter absorbs any moisture in the vent tube to keep vapor from condensing. The installation of the desiccant drying cartridge is quick and easy. Common installation methods are cable tie, Velcro, and cable clamps.

NOTE: Desiccant crystals change from blue to pink as they become saturated. Cartridge must be replaced when all crystals have saturated.

IMPORTANT: Do NOT use desiccant cartridge in the presence of vapors of liquids containing phosphate esters, synthetic lubricant, hydrocarbon solvents, methanol, acetone, lacquer solvents, or other organics.

8 Wiring Information

PT-503 Series Pin Out Table

Pigtail	4-20 mA		0.5 – 4.5 VDC	
	Red	+ Power/Signal	+ Power	
	Black	- Power/Signal	Common	
	Yellow	n/a	+ Out	

WARNING: When wiring the PT-503 L20 Ratiometric system, do NOT exceed 5.5 Volts DC. Excessive voltage will result in permanent damage to the sensor and void the warranty.

PT-503 Series Supply Power Table

	4-20 mA	0.5 – 4.5 VDC
Power Supply	9-30 VDC	4.5 – 5.5 VDC

PT-503 L1 4-20 mA System Wiring

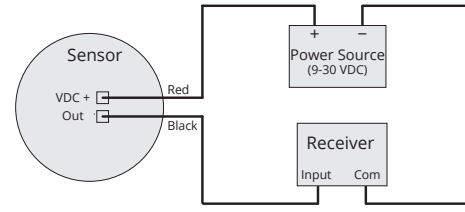

PT-503 L20 Voltage System Wiring

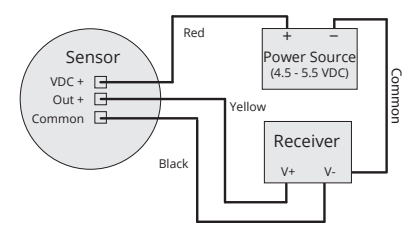

9 Removal Instructions

Removing your PT-503 from service must be done with care. It's easy to damage your sensor, if you are not careful to follow these guidelines:

- Retrieve the sensor from the vessel. Follow any and all procedures for safely isolating any media contained inside the line or vessel.
- Carefully clean the sensor's fitting and diaphragm of any debris (see General Care) and inspect for damage.
- Store your sensor in a dry place, at a temperature between -40° F and 180° F.